

# Goudhurst Parish Council



## Amenities Committee 2nd July 2024

MEETING  
2 July 2024 19:30 BST

PUBLISHED  
26 June 2024

# Goudhurst Parish Council



To: Cllrs David Knight (Chairman), Suzie Kember, Geoff Mason, Ed Read-Cutting, Caroline Richards and Mrs Alison Webster. Antony Harris (Ex Officio)

I summon you to a Meeting of the Amenities Committee on Tuesday 2<sup>nd</sup> July 7.30 pm, in the Church Rooms, where business detailed on this agenda will be discussed.

**Goudhurst Parish Council recognise that there are continuing risks associated with COVID-19 and are supportive of individuals wearing masks in meetings and maintaining a social distance. We will continue to provide hand sanitiser at the entrance to the Village Hall. In order to keep everyone safe, please do not attend a meeting if you have COVID-19 symptoms or have tested positive for COVID-19 in the past 5 days. We will continue to review the risks and will comply with any future controls recommended or mandated by HM Government.**

**Members of the Public and the Press are welcome to attend this meeting.** At the Chairman's discretion, 15 minutes will be set aside for questions from members of the public each one of whom may be invited to speak for a maximum of 3 minutes in total relating to items on the Agenda or about issues of local concern. Thereafter they have the right, and are welcome, to stay and observe the rest of the Meeting in accordance with the Public Bodies (Admission to Meetings) Act 1960, s1.

Please inform the Assistant Clerk if you intend to film or record the Meeting.



Katrina Hoyle  
Acting Clerk to Goudhurst Parish Council  
25<sup>th</sup> June 2024

Parish Council Office - The Hop Bine, Ranters Lane, Goudhurst, TN17 1HN  
01580 212552 | [clerk@goudhurst-pc.gov.uk](mailto:clerk@goudhurst-pc.gov.uk) | <https://goudhurst-pc.gov.uk> | 0753 438 4712

A quorum for Amenities Committee is 3 Members.

# Agenda

Location  
Church Rooms, Back Lane, Goudhurst, Kent

Date  
2 Jul 2024

Time  
19:30 BST

	Item	Page
1	Apologies for Absence	-
2	Declarations of Interest	-
3	To elect a Vice Chair	-
4	To resolve to approve the minutes of the meeting held on 28th May 2024	5
5	To resolve to co-opt Paul Wareham as an additional member of the Amenities Committee	-
6	Questions from the press and public.	-
7	To receive an update on:-	-
7.1	the AED in the old phonebox	-
7.2	the Millenium Walk sign posting and discs	-
7.3	the removal and painting of the Village Sign	-
7.4	the replacement bench on The Plain	-
7.5	the water treatment of the pond of The Plain	-
7.6	the Duck House	-
8	To resolve to decide how to utilise the modern phone box.	-
9	Receive feedback on the litter bin collection from TWBC	-
10	To receive feedback on the investigation of one, unified CCTV System and decide any action needed.	-
11	To receive feedback on the outside gym and decide on any action required	8
12	To discuss feedback on the Petanque pitch and decide on action required	-
13	To discuss the maintenance of the public car park at Balcombes Hill and decide on any action required	-
14	To discuss the request to supply a bench for the Lower Glebe and decide on any action required	-
15	To resolve the expenditure of up to £1,120 (£280 per visit, up to four visits) to treat the duck weed on the pond at the Quarry Pond	82
16	To resolve the expenditure of £180 for the removal of the tree at the Quarry Pond	-
17	To discuss and approve moving the bike rack on Balcombes Hill	-

	Item	Page
18	To discuss the existing the dog waste dispensers and decide any action needed.	-
19	Items for information.	-
19.1	Map for the website	-
19.2	Planters at the public toilets	-
20	Date of next Amenities Committee Meeting, Tuesday 27th August 2024, 7.30pm Church Rooms, Back Lane.	-

# Goudhurst Parish Council



## AMENITIES COMMITTEE

Minutes of a Meeting held on 28<sup>th</sup> May 2024 at 7.30pm in The Church Rooms, Back Lane.

### PARTICIPANTS

*Councillors Present:* Cllrs David Knight, Antony Harris, Caroline Richards, Alison Webster, and Ed Read-Cutting.

*Officers Present:* Rebecca Barden, Assistant Clerk

### APOLOGIES

106/24 Cllrs Geoff Mason and Julia Kiggell sent their apologies.

### DISCLOSURES OF INTEREST

107/24 There were none.

### MINUTES OF THE LAST MEETING

108/24 It was resolved the minutes of the Amenities Committee meeting held on 27<sup>th</sup> February 2024, and previously distributed to members via Board Intelligence, be accepted as a correct record.

### QUESTIONS FROM THE PUBLIC AND PRESS

109/24 There were none.

### MATTERS FOR CONSIDERATION

110/24 ***To Elect a Chairman of the Amenities Committee***

Cllr Alison Webster proposed Cllr David Knight, Cllr Caroline Richards seconded and this was unanimously agreed by those present. **Resolved:** Cllr David Knight is the Chairman of the Amenities Committee.

111/24 ***To Resolve to Co-opt Cllr Suzie Kember as an additional member of the Amenities Committee***

Cllr David Knight explained that Cllr Suzie Kember had expressed an interest in joining the Amenities Committee. **Resolved:** Cllr Suzie Kember be added as an additional member of the Amenities Committee. **Action: Assistant Clerk to update website, noticeboards.**

112/24 ***To receive an update and make a decision on painting the new Goudhurst phone box***

The Assistant Clerk gave an update regarding the feedback from the painters that had been asked to quote. There was a discussion regarding the possibility of replacing the new phone box with an old-style telephone box and whether the defibrillator could be installed in the old-style phone box. The Assistant Clerk informed the Committee that there had been discussion of social media regarding using the new box as a book exchange. Cllr Webster stated that there was already a book exchange in the Social Club. Cllr Harris to add this information in the June Newsletter. **Action:** Assistant Clerk to establish whether the defibrillator could be installed in the old phone box.

113/24 ***To Resolve to appoint a contractor to install the AED in the old phonebox***

The Assistant Clerk informed the Committee that B&K had quoted for the work. **Resolved:** B&K be appointed to install the AED to be paid from budget code 5108. **Action:** Assistant Clerk to liaise with Cllr Kirkby.

114/24 ***To receive an update on the Millennium Walk sign posting, including the number of posts required and decide on any action needed***

- Cllr Richards walked the route last week and identified where the new information discs could be installed and whether any new posts were required. **Resolved:** It was agreed that expenditure of up to £200 was acceptable. **Action:** Cllr Richards to order 45 information discs from Iden Signs. **Resolved:** to be paid from budget code 5382.
- 115/24 ***To resolve the expenditure of £850 for painting the village sign on The Plain***  
Cllr Knight explained that the Parish Council need to take the sign down and taken to A&C Blasting Services. It was also noted that the supporting post needs to be replaced. There was discussion whether the new post should be oak or composite and also the location of the sign. **Resolved:** Assistant Clerk to arrange for the sign to be taken down and taken to A&C Blasting Services and to obtain quotes for the replacement post. **Resolved:** It was resolved to approve the expenditure of £850 for the painting of the village sign on The Plain and be paid from budget code 5325. **Action:** Assistant Clerk to obtain quotes for replacement post and action sign removal and repair.
- 116/24 ***To resolve to replace the damaged bench on The Plain.***  
There was a discussion to identify which bench was damaged and what the damage was. **Resolved:** to replace the damaged bench on The Plain and be paid from budget code 5325. **Action:** Assistant Clerk to order replacement bench.
- 117/24 ***To resolve the expenditure of £950 for Kilndown The Quarry and £750 for the Village Pond for water treatment***  
Cllr Webster explained that she had a site visit with Marion Sargeant who provided a lot of very useful knowledge regarding the drainage, filters for the village pond. Assistant Clerk updated the Committee that the water treatment for the Quarry Pond could not be carried out until the pond has been cleared. **Resolved:** Cllr Read-Cutting to liaise with Marion Sargeant (Goudhurst Village pond) and Tony Bovey (Quarry Pond) and for the payment to be made from budget code 5300. **Action:** Cllr Harris to provide contact details for Cllr Read-Cutting. Cllr Read-Cutting to contact Marion and Tony. Assistant Clerk to arrange water treatment for the village pond.
- 118/24 ***To receive an update regarding The Plain Information Board and decide on any further action needed.***  
Cllr Wester informed the Committee that the sign was in the process of being made and everything was moving forward. **Resolved:** to be paid from reserves.
- 119/24 ***To receive an update and decide on any action needed regarding the Duck House.***  
Assistant Clerk gave an update on the work being carried out on the Duck House. **Action:** Assistant Clerk to chase up contractor with a view to having it repaired and returned to the pond ASAP. **Resolved:** to be paid from budget code 5300.
- 120/24 ***To receive feedback on the litter bin collection from TWBC and decide on any action needed.***  
**Action:** Assistant Clerk to check progress with TWBC.
- 121/24 ***To resolve the addition of two Goudhurst Village Hall cameras on the Goudhurst Parish Council system.***  
There was a discussion regarding the current CCTV provision and its effectiveness. It was **resolved** for Cllr Webster to contact the current providers and discuss the issues. **Action:** Assistant Clerk to email Hall BT letter to Cllr Knight. Cllr Kirkby and Cllr Hodgskin to contact Village Hall Committee and identify need.
- 122/24 ***To resolve to re-instigate the investigation of one, unified CCTV system.***  
Cllr Webster asked whether this should take place when the Parish Council move to the new office. **Action:** Cllr Webster to liaise with current provider.
- 123/24 ***To resolve to keep the spare St Mary's Days Garage for Parish Council storage.***  
**Resolved:** to keep the spare St Mary's Days Garage for Parish Council storage.
- 124/24 ***To discuss and make a decision on next steps for the outside gym.***

The Committee are positive about this issue but are concerned about the costs. **Action:** Assistant Clerk to investigate costings, discuss funding with the RFO. Assistant Clerk to add the Petanque Pitch to the next Amenities Committee Agenda. **Resolved:** any costs would come out of reserves.

125/24 ***To resolve to tidy the trough on The Plain and decide on any action needed.***

It was noted that Cllr Webster and Marion Sargeant had visited the trough and tidied and cleaned it the previous week and the Assistant Clerk had purchased and planted up bedding plants in the trough that weekend. The Committee passed on their thanks for this work.

There was discussion regarding the trimming of overhead branches.

**Action:** Assistant Clerk to arrange for contractor to trim overhead branches. **Resolved:** expenses to be paid from budget code 5300.

ITEMS FOR INFORMATION

126/24 ***Goudhurst Parish In Bloom***

The Assistant Clerk gave an update on the progress of this event and encouraged everyone to enter. **Action:** Assistant Clerk to issue more posters and Cllr Knight to provide a poster for The Quarry Centre.

127/24 ***Goudhurst Parish Residents' Survey***

The results of the Parish Survey were discussed briefly and the need to analyse the results and allocate these to the appropriate committees was agreed. It was suggested that Cllr Broom undertook this analysis. **Action:** Assistant Clerk to inform Cllr Broom.

DATE OF THE NEXT MEETING

Next Amenities Committee Meeting on Tuesday 2nd July 2024.

The meeting closed at 8.42pm

Rebecca Barden  
Assistant Clerk  
28<sup>th</sup> May



**World class outdoor gyms** for  
**Activating communities** with  
**Quality equipment** that's  
**Made in Britain**

.....  
**Tender Appendices**  
**Outdoor Gym Concept - Vision Board**  
 Capel Parish Council  
 .....





# Introduction

---

## Thank you!

We are delighted to present our visions and designs for the outdoor gym for Capel Parish Council.

TGO create gyms that help communities become healthier and more sustainable. Our mantra is **Healthy People, Healthy Planet.**

We have installed over 3000 outdoor gyms worldwide which provide a sustainable inclusive way to unlock the power of movement. All our submission designs have been created through our 15 years' experience in developing outdoor gym solutions across the UK and the world.

We pride ourselves in working closely with our customers to develop inclusive outdoor gym spaces that encourage whole communities to be stronger, together.

**This document will show how we will create a gym that will be an inclusive and social 'community hub,' designed to be welcoming, approachable and encourage repeat use.**

See our vision [here](#)





# Who Are We?

.....

We are the Great Outdoor Gym Company. We are not a Playground equipment company that sells gym equipment as a 'bolt on' to Playgrounds. Our core speciality and expertise is in outdoor gyms, and we design them for whole communities.

Formed in 2007, The Great Outdoor Gym Company (TGO) is the worldwide pioneer in safer, high quality and inclusive outdoor gyms. We have successfully installed in excess of 3000 sites so far across the globe. Made in Britain, TGO has always done the right thing by quality, safety and innovation. TGO designs, supplies, installs and maintains outdoor gyms. At our heart are values of care, high principles and vision. The business has grown significantly over the past 15 years, but it is still a family run business, owned and ran by Matt Delaney (former Regional Director of London at Sport England) and Georgie Delaney (MBE).

The TGO group consists of two sister companies, The Great Outdoor Gym Company (TGO) which is the equipment manufacturing and distribution company and TGO Activate, the activation and digital platform arm. Both of these elements will work in unison on your gym.

TGO is also an export champion for The Department of International Trade (DIT) . Our gyms can be found in every corner of the globe, from Jumeirah Beach in Dubai, to Randwick Sydney Coastal Walk in Australia, Metro plaza Hong Kong, and Gardens by the Bay Singapore. These sites alone have around 50 millions of visitors per year. It is estimated that 60 million people come across and interact with TGO gyms each year. TGO's contribution to export was recognised when co-founder, Georgie Delaney received an MBE in 2022.



# Innovators and leaders in outdoor gyms

TGO was specialising in outdoor gyms before all other UK companies. Our ethos is to do the right thing in safety, quality, functionality, and inclusivity. We have led the industry in all these areas and for that reason the BSI approached us initially prior to the creation of the European standard.

- 1 Leaders on **QUALITY** - British made, and designed products
- 2 Leaders in the industry of outdoor fitness **SAFETY** worldwide
- 3 Leaders for best **INNOVATIVE DESIGNS** and most comprehensive Calisthenics (Street Workout) range
- 4 Leaders in **INCLUSIVE** equipment for all abilities and progression including wheelchair users
- 5 Leaders in **SUSTAINABILITY** by planting trees and generating people power!

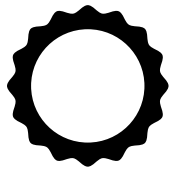

Designed by health and fitness professionals



Made in Britain



Safer



Inclusive



Generates electricity and it's even Smart



# Our Story

## The TGO Group

The Great Outdoor Gym Company (TGO) which is the equipment company and TGO activate, the activation and digital platform arm. Formed in 2007, The Great Outdoor Gym Company (TGO) is the worldwide pioneer in safer, energy generating, inclusive outdoor gyms, installing in excess of **2000 sites** so far globally. **Made in Britain**, TGO has always done the right thing by **quality, safety** and **innovation**. TGO designs, supplies, installs and maintains outdoor gyms.

## Export champion

The Department of International Trade (DIT) have recognised TGO as a prestigious 'export champion'. Our gyms can be found in every corner of the globe from Jumeirah Beach in Dubai, to Randwick Sydney Coastal Walk in Australia, Metro plaza Hong Kong, and Gardens by the Bay Singapore. These sites alone have around 50 millions of visitors per year. It is estimated that 60 million people come across and interact with TGO gyms each year.



Scan to find out



TGO deliver 70 x Olympic branded gyms for Adidas



TGO invent gyms that generate electricity and a human energy storage system (EDU)



2007

2008  
2012

2009

2012

2012  
2017



TGO Gym incorporate



TGO move manufacturing to the UK



TGO lands in Dubai, Sydney, Singapore, Hong Kong... and many more

# Our Story



**TGO's energy gyms are featured at Paris Climate change conference**

2015



**Develop Smart data**

2016

2017

2018



**TGO pioneer free classes**

2020



**Founder of TGO, Georgie Delaney is awarded an MBE**

2021

2022

## Manufactured in the UK

We are proud to be 100% manufactured in Britain, TGO is a British success story. Behind TGO and TGO activate is a dynamic and experienced team that have achieved a huge amount. At the heart of TGO are values of care, doing the right thing and vision.

The business has grown over the past 15 years but it is still a family run business with Matt Delaney (former Sport England Director) and Georgie Delaney who in 2021, was honoured with an MBE for her work in trade and export.



**Commissioned by the UN as a legacy project of COP22**



**TGO creates a gym out of recycled aerosol cans for Right Guard**



**Kevin McCloud picks TGO again as one of his all-time favourite Green Heroes**



**Over 3000 gyms installed and new vision of healthy people and healthy planet....**



# What our customers say



"I've worked with TGO over a number of years on a number of projects and I know their service is second to none. The impact that this activity zone has had has already been beyond belief because there is something for everyone."

**Lisa Dodd-Mayne, Director of Sport and Active Communities, University of Warwick**



www.slough.gov.uk  
**Slough**  
Borough Council

"The green gyms have been a major success with residents. Their popularity is due to the enormous effort of TGO and the council, working together with local people to identify the very best equipment for their needs. The quality of the equipment is exceptional too."

**Alison Hibbert, Leisure Services Manger at Slough Borough Council**



# What sets TGO apart

- ✓ TGO gyms are safer
- ✓ TGO gyms are stronger
- ✓ TGO gyms are more sustainable
- ✓ TGO gyms are smarter
- ✓ TGO gyms are more inclusive market
- ✓ TGO gyms are more family friendly
- ✓ TGO gyms are activation friendlier
- ✓ TGO gyms cater for all fitness abilities
- ✓ TGO gyms come with the most experience
- ✓ TGO gyms are the best value on the market



Image: Freddie Flintoff and Jamie Redknapp at Queen Elizabeth Olympic Park, Right Guard TGO gym

# Capel Parish Council



## Community Gym Proposal

### Your gym, designed by experts, accessible by the whole community:

Our expertise has been applied to create your gym and it is designed to be **accessible** to your whole community. The family friendly design is intended to be a **social hub**. It caters for every fitness level, and for those with disabilities.

The **inclusive features**, such as ample space between equipment which creates wide pathways for ease of movement, make the space welcoming and **family friendly**. The equipment, the gym area, and the surfacing encourage the **community** to enjoy social time together, through activities where parents, grandparents, and young people of **all abilities** can all participate in physical activity **together**.





# Contract Pledge - Capel Parish Council

TGO have vast experience in developing successful partnerships. We wish to make it clear that through every phase of the process, it is our intention to develop a close working relationship, partnering up over the same objective - to develop a world class fitness and wellness facility that the whole community will love for years to come.

Together, we will co-create success in your outdoor gym at Capel Parish Council. We understand that the only way to achieve outstanding results is to create a positive culture of quality in every aspect of the delivery process, including:

- Expert project delivery and ongoing account management
- Inclusive equipment designed for all abilities





# Render in Situ - Capel Parish Council - Option One





# Overview Render - Capel Parish Council - Option One

## Gym Equipment

- 1. Time Together Rig
- 2. Cross Trainer
- 3. Hand Bike

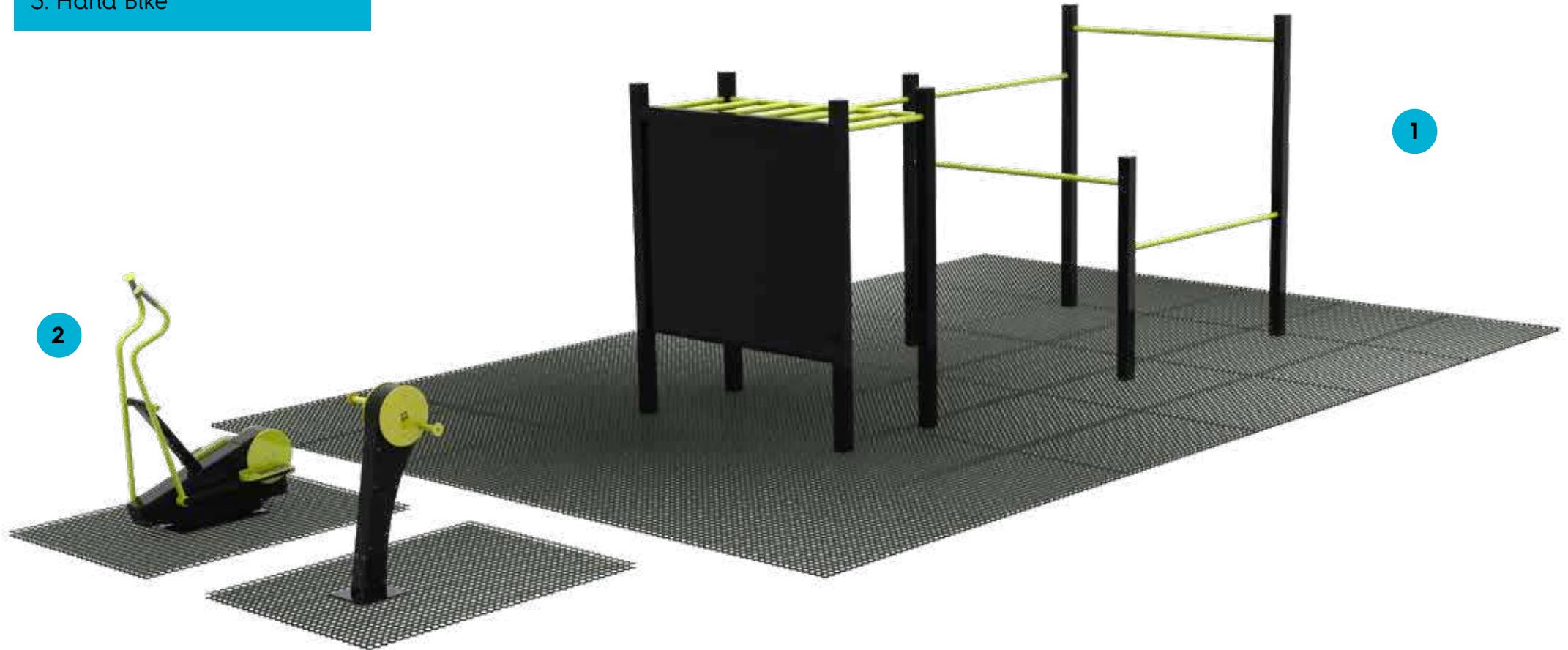

# Gym Equipment - Capel Parish Council - Option One

## 1. Time Together Rig

(Developed in conjunction with the Women in Sport Campaign Time together) which includes:

- 4 x 2m wide varying height bars accessible to all
- Show bar
- 2m x 1m wide monkey bar
- Handstand wall

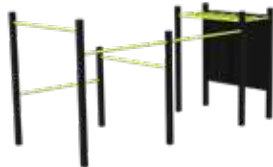

## 2. FS861 Cross Trainer

On this stylish cross trainer, the user will get a cardiovascular workout, as well as helping to improve muscle tone in the legs, arms and core. With top quality bearings and sliding mechanisms the TGO cross trainer is smooth, safe and easy to use. From super fit to those new to exercise, this is the perfect piece for any gym. Over the years this has proven to be one of our most popular pieces.



## 3. FS907 Hand Bike

All TGO products are designed to be as inclusive as possible but the Hand Bike is one of TGO's star pieces for inclusivity. This piece can be used by both able bodied users and wheelchair users. It is an excellent cardiovascular piece of equipment, toning up arms and shoulders whilst improving strength, stamina and endurance.





# Gym Equipment - Capel Parish Council - Option One

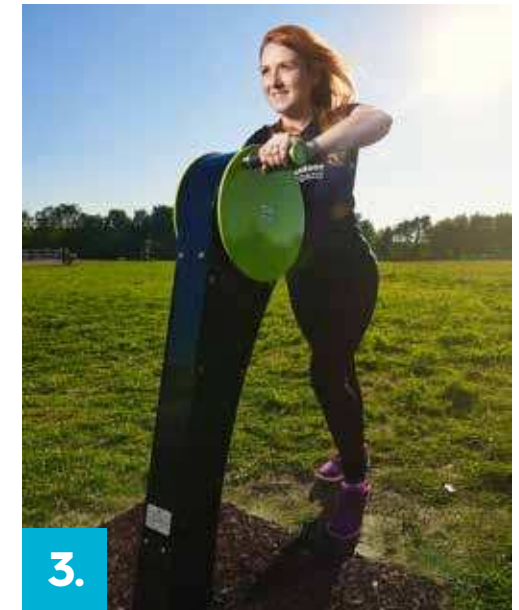
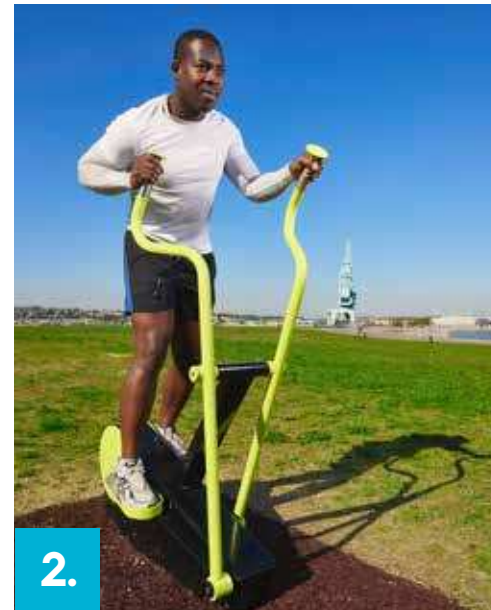



# Render in Situ - Capel Parish Council - Option Two

.....





# Overview Render - Capel Parish Council - Option Two

## Gym Equipment

1. Hand Bike
2. Cross Trainer
3. Lat Pull Down/Shoulder Press
4. Dips/Leg Raise
5. Plyometric Boxes
6. Double Pull Up Bar



# Gym Equipment - Capel Parish Council - Option Two

## 1. FS907 Hand Bike

All TGO products are designed to be as inclusive as possible but the Hand Bike is one of TGO's star pieces for inclusivity. This piece can be used by both able bodied users and wheelchair users. It is an excellent cardiovascular piece of equipment, toning up arms and shoulders whilst improving strength, stamina and endurance.



## 2. FS861 Cross Trainer

On this stylish cross trainer, the user will get a cardiovascular workout, as well as helping to improve muscle tone in the legs, arms and core. With top quality bearings and sliding mechanisms the TGO cross trainer is smooth, safe and easy to use. From super fit to those new to exercise, this is the perfect piece for any gym. Over the years this has proven to be one of our most popular pieces.



## 3. FS825 Lat Pull Down/Shoulder Press

The lat pull down and shoulder press forms the centre piece of many TGO gyms. Based on lifting approximately 30% of your body weight, this machine works the chest, arms, shoulders and back (upper to middle) giving a great upper body workout for all abilities.



## 4. FS800 Dips/Leg Raise

This piece of equipment is two stunning exercises for the price and space of one. This not only has an improved 'dips' exercise on one side but also has the more inclusive 'leg raise' exercise on the other side. The leg raise is an excellent way to improve your core strength. The dips is for the fitness fanatic who will visit the gym especially to use this piece and be very grateful! The dips improve the tone of the upper body in particular arms and shoulders.



## 5. FS841 Plyometric Boxes

Jump to it with TGO's all new Plyometric boxes. Great for the super-fit to the new user, these are a fantastic addition to your gym giving an excellent cardiovascular work out. Improving heart and lung function as well as improving leg strength and overall tone.

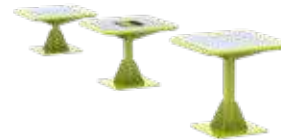

## 6. FS502 Double Pull Up Bar

Targets multiple muscle groups such as back and bicep muscles, and can improve posture. A compound exercise, therefore improving functional strength. Also great for an after workout stretch.





# Gym Equipment - Capel Parish Council - Option Two

.....

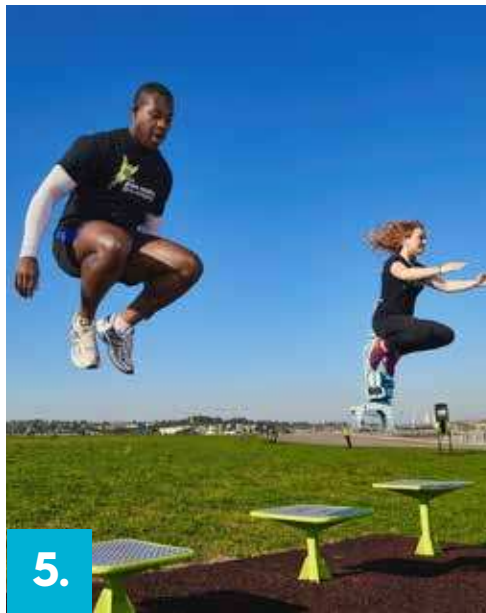
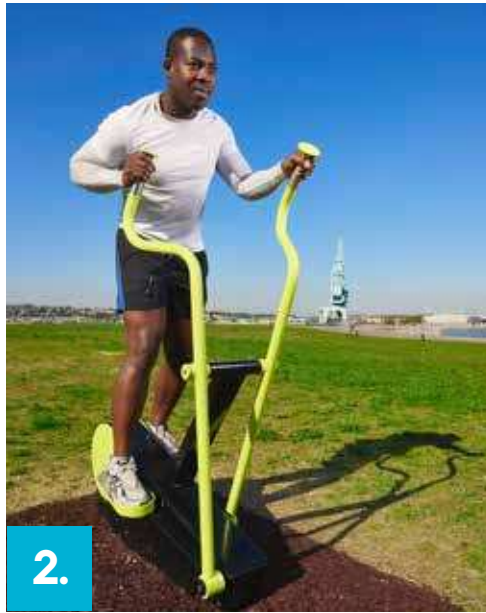



# Table Tennis - Capel Parish Council - Location One

.....





# Table Tennis - Capel Parish Council - Location Two

.....









# Gym Equipment - Capel Parish Council

.....



## **Your gym is accessible and inclusive for all users**

Variety, adaptability and welcoming by design - Although specific benefits and suitability may vary depending on the type and severity of individuals' disability, the equipment we select in designs can be used to accommodate various ability levels. TGO follows the Inclusive Fitness Initiative (IFI) in all its designs, meaning that people with different abilities can use the same equipment. This allows for exercises to be progressive, starting at easy levels of exercise, to expert, and everything in between. We also have our Legacy range, with wide seats, highly visible handles and access points, grips for assistance and large bar ends for safety. Additionally, the Hand Bike is wheelchair accessible through its unique design.



# Gym Equipment - Capel Parish Council



## Adult Groups

Fitness, Strength and Wellness - Your gym will provide a convenient and accessible means to the community for of social and engaging workouts. The variations and adaptations in our gym equipment provide fitness and strength training exercises that are accessible to all abilities and progressive from beginner to advance. It allows for a full-body workout without the need for variable weight machines. The significant variety of exercises your gym offers will allow for the varying abilities within a community the choice to train individually or together, each on their own fitness and wellness journey.



# Gym Equipment - Capel Parish Council

.....



## Older Adults

Flexibility, balance and strength are fundamental to maintaining a healthy and happy lifestyle. Exercises performed on our gym can cater to the needs of seniors, providing a low-impact form of exercise that helps maintain these into later life. All TGO Equipment can provide ample opportunities for training that promotes wellness into later life.



# Gym Equipment - Capel Parish Council



## Mental Health and Wellness

We fully understand that wellness from togetherness and inclusive activity benefits mental health, and this is well documented. Our gyms offer each community a central point that will benefit both their physical and mental well-being. Stress reduction, improved self-esteem, and increase confidence through social interaction is made available. These benefits can be particularly important for individuals with disabilities, as they may face additional challenges in their everyday lives. Community engagement is a central pillar to the success of this. The welcoming gym designs we offer creates a community 'hub'. People of all abilities can come together to exercise, socialise, and engage with each other. This sense of community can be especially valuable for individuals with disabilities, as it promotes an inclusive and supportive environment.

**Inclusivity:** Features are built into the design of all our equipment in accordance with Inclusive Fitness Initiative (IFI) guidelines. This creates usable equipment regardless of age or ability. This will ensure the facility is highly accessible for people with special educational needs or disabilities.

Key elements of the **IFI standard in the design** of our equipment (as shown in the images below):

1. Low seat heights with easy access and no step up to use legacy strength equipment
2. Touch points with tactile designs to indicate proper use
3. High colour contrast for touch points
4. Round ball ends to handles prevent low grip slips
5. Large, high grip pedals on bikes
6. Contrasting colours with large font on signage
7. Step through design in recumbent bikes
8. Swing away seats where possible
9. Audible equipment instructions in the app (YouTube videos)
10. Wide and deep seats that include additional grip points where possible
11. Transfer handles and bars where possible for supported equipment access
12. Large diameter touch points for increased surface area for grip support







# Your Gym Signage

- ✓ Signage QR codes link user to TGO Activate App.
- ✓ QR codes on signage to log and track workouts.
- ✓ Signage graphics to display how to use equipment.
- ✓ 'Activate' App enables users to find their TGO gym, log and track workouts and share with friends on social media
- ✓ Educational signage



Click here to download the TGO Activate App



All the signage comes with a QR codes. This QR code enables you Download the TGO Activate app to log your workout and shows you select a video tutorial on that particular piece.

# Your gym is Stronger

.....

We pride ourselves on our quality. We moved our manufacturing back to the UK in 2012 to control the quality, ensure the materials are to spec and ensure the workmanship is to British standards across the TGO range. This gives us a confidence to offer the following warranty:

- ✓ **25 warranty on metalwork**
- ✓ **5 year warranty on paintwork**
- ✓ **2 year warranty on bearings**
- ✓ **5 year warranty on green energy gym electronics**
- ✓ **2 year warranty on plastic or composite parts, seats, fittings and clamps**

- Made in the UK
- Load and cyclical Testing
- TGO fixings are anti-vandal and anti-tamper
- CE marked steel
- Welds certified to BSEN ISO 15614
- All TGO Equipment is E-Coated same technique as car industry

 **MADE IN BRITAIN**

**We're Stronger**





# Your gym is Made in Britain

- ✓ 25 year warranty on structural steel
- ✓ Installed worldwide
- ✓ Load and cyclical testing
- ✓ TGO fixings are anti-vandal and anti-tamper
- ✓ CE marked steel
- ✓ Welds certified to BSEN ISO 15614
- ✓ Built-in resistance to offer great health outcomes



Spinning Bikes in production



Hand Bike in production



# TGO Manufacturing process



All TGO equipment is manufactured in our UK factories (one in Gateshead and one in Selby)



UK Sourced Materials – 99% of our component part materials is sourced within the UK meaning we have tighter control over our production and supply. Raw materials and parts are bulk ordered with high re-order levels to ensure we are never without stock of materials & parts.



Parts Fabrication – we are continually making batches of component parts for our products. Once an order is received it is added to the Production Schedule for parts to be picked and sent to the Paint Shop.



Painting Process – all parts are primed and powder coated in house through our paint plant.



Assembly – once parts are painted they are assembled to build the products in our Assembly area.



Quality Control – at all stages of the manufacture parts are quality checked. The products received a final quality check before they are palletised & wrapped ready for dispatch.

# Your gym is Sustainable

At TGO we have a healthy people and healthy planet vision!

- ✓ We recycle human energy with our energy range!
- ✓ We plant 10 trees for every piece of equipment we install and 100 trees for rigs. This ensures the facility is offset.
- ✓ TGO Cardio Charge products charge up smart phones and other devices via USB port or contactless plate.
- ✓ Unique console on every TGO Cardio Charge piece. Includes watt counter that lights up in use for motivational boost and wow factor
- ✓ No need to disturb the groundwork if you want to upgrade as we have designed special bases
- ✓ TGO gyms are made to last - By manufacturing in the UK, we ensure a long lasting product that will stand the test of time. If supplying to the UK, this also means less transportation than our competitors.



TGO have already planted 50k trees with the vision to plant millions more as TGO plant 10 trees for every piece of equipment installed

## We plant a tree for every piece we install!

in the UK



Kevin McCloud from Grand Designs picks TGO multiply years running as one of his all-time favourite Green Heroes



# Your gym is Safer

- ✓ TGO equipment is compliant with BS EN16630:2015
- ✓ All TGO stop mechanisms are concealed
- ✓ All moving parts are limited in their movement
- ✓ All moving elements are within the framework of the equipment
- ✓ All TGO equipment is free of crush points, entrapment points, shear-points and sharp edges



# TGO maintenance and spare parts

## Maintenance requirements

The TGO product range has been designed to require very little maintenance to keep it running smoothly and looking great. However, as many of the pieces have moving parts these will need light maintenance

To keep everything operating as they should this involves some basic daily/weekly/monthly inspections of the equipment, for example, checks for any vandalism or faults, lubrication of moving parts, touching up of any paintwork damage.

We provide you with a 'Light Maintenance Kit' which includes a maintenance manual, correct fixing tools, lubrication oil and touch up paints.



## Spares / replacements

TGO can offer an extensive maintenance pack on substantial orders so that spares that may be required are available from that pack immediately (this will include touch up paint, spare fixtures and fittings, bearings etc). Anything from that pack that is used within the warranty period will be replaced FOC (all our stock and spare parts are all made in the UK so lead time is short and no long shipment delays!)

We will keep a record of the detailed specification of your equipment to ensure the spares for your equipment are available for the duration of the contract.

### The benefit of TGO with spares/ Replacements:

1. We manufacture here in the UK
2. Many of our parts are common to each piece
3. Lead time on common spares will be in most cases under 72 hours if not less.

Spares Kits	Per Product	Partner Pack
Cross Trainer	<ul style="list-style-type: none"> <li>4x MS Cage Nut – For clads</li> <li>1x Plastic Bung - Rear End</li> <li>2x M8x16 Pinhead Torx CSN'K – Clads</li> <li>2x M8x20 Pinhead Torx CSN'K – End caps</li> <li>2x M8x20 Pinhead Hex Underlays CSN'K – Central fix</li> <li>1x M8x16 Pinhead Torx Button – Rear Clad</li> <li>1x MS Washer – Rear Clad</li> </ul>	<ul style="list-style-type: none"> <li>2x Drive - 117, 181, 19 FDB - Rear Plank/Handle Pivot</li> <li>1x GSK - 60x40x25-L2</li> <li>1x End Cap - TGOGC3-A-03-05</li> <li>1x Fitness Plate - TGOGC23-11</li> </ul>
Hand Bike	<ul style="list-style-type: none"> <li>1x M8x20 Pinhead Torx CSN'K – Pedal end cap</li> <li>2x M8x16 - Clads</li> <li>1x M8x16 Pinhead Torx Button Head – Top clad</li> <li>2x M8x20 Pinhead Torx CSN'K – Clads</li> <li>2x M8x20 Pinhead Hex CSN'K – Central fix</li> </ul>	<ul style="list-style-type: none"> <li>1x Handle Asm - TGOGC87-A-03</li> <li>1x Handle End Cap - TGOGC87-01</li> <li>1x Fitness Plate - TGOGC23-11</li> </ul>
Spinning Bike	<ul style="list-style-type: none"> <li>1x M8x20 Pinhead Torx CSN'K – Pedal end cap</li> <li>1x M8x16 Pinhead Torx Button Head – Top clad</li> <li>2x M8x16 Pinhead Torx CSN'K – Clads</li> <li>2x M8x20 Pinhead Hex CSN'K – Central fix</li> </ul>	<ul style="list-style-type: none"> <li>1x Pedal Asm - TGOGC07-017</li> <li>1x End Cap - TGOGC88-06</li> <li>1x Fitness Plate - TGOGC23-11</li> </ul>
Recumbent Bike	<ul style="list-style-type: none"> <li>1x M8x20 Pinhead Torx CSN'K – Pedal end cap</li> <li>2x M8x16 - Clads</li> <li>1x M8x16 Pinhead Torx Button Head – Top clad</li> <li>2x M8x20 Pinhead Torx CSN'K – Clads</li> <li>2x M8x20 Pinhead Hex CSN'K – Central fix</li> </ul>	<ul style="list-style-type: none"> <li>1x Pedal Asm - TGOGC07-017</li> <li>1x Handle End Cap - TGOGC88-06</li> <li>1x Fitness Plate - TGOGC23-11</li> </ul>
Module	<ul style="list-style-type: none"> <li>Per Product</li> </ul>	<ul style="list-style-type: none"> <li>Partner Pack</li> <li>2x Central Bearing Housing Assembly</li> <li>1x Brake Asm - TGOGC84-A-04</li> </ul>
Phyometric Box	<ul style="list-style-type: none"> <li>Per Product</li> </ul>	<ul style="list-style-type: none"> <li>Partner Pack</li> </ul>
N/A	<ul style="list-style-type: none"> <li>Per Product</li> </ul>	<ul style="list-style-type: none"> <li>Partner Pack</li> </ul>
Leg Press	<ul style="list-style-type: none"> <li>Per Product</li> </ul>	<ul style="list-style-type: none"> <li>Partner Pack</li> <li>1x Track Wheel - 251496 POTH 75_15R</li> <li>1x Bump Stop</li> </ul>
Treadmill	<ul style="list-style-type: none"> <li>Per Product</li> </ul>	<ul style="list-style-type: none"> <li>Partner Pack</li> </ul>
N/A	<ul style="list-style-type: none"> <li>Per Product</li> </ul>	<ul style="list-style-type: none"> <li>Partner Pack</li> </ul>
Step Up	<ul style="list-style-type: none"> <li>Per Product</li> </ul>	<ul style="list-style-type: none"> <li>Partner Pack</li> </ul>
Oblique	<ul style="list-style-type: none"> <li>Per Product</li> </ul>	<ul style="list-style-type: none"> <li>Partner Pack</li> <li>2x MS CSK Security Screw (A2)</li> <li>2x MS Washer (A2)</li> <li>2x MS Nylon</li> </ul>
Bench	<ul style="list-style-type: none"> <li>Per Product</li> </ul>	<ul style="list-style-type: none"> <li>Partner Pack</li> <li>2x M8x25 Button Security Screw (A2)</li> <li>2x MS Washers (A2)</li> </ul>
Dip and Leg Raise	<ul style="list-style-type: none"> <li>Per Product</li> </ul>	<ul style="list-style-type: none"> <li>Partner Pack</li> <li>2x M8x25 Button Security Screw (A2)</li> <li>2x MS Washers (A2)</li> <li>1x M8x16 Button Security Screw (A2)</li> <li>1x MS Washer (A2)</li> </ul>
Ski Machine	<ul style="list-style-type: none"> <li>Per Product</li> </ul>	<ul style="list-style-type: none"> <li>Partner Pack</li> <li>1x TGOGC72-01</li> <li>2x M8x20 Security Button security screw (A2)</li> <li>1x M8x20 Security CSK screw (A2)</li> <li>1x MS Washer (A2)</li> <li>1x MS Nylon</li> </ul>
CP/R	<ul style="list-style-type: none"> <li>Per Product</li> </ul>	<ul style="list-style-type: none"> <li>Partner Pack</li> <li>2x M8x25 Button Security (A2) - Seats &amp; Backs</li> <li>1x End Cap - TGOGC72-01</li> </ul>

### Energy Recumbent Bike TGO892

It may be necessary at some stage to maintain and access the Parasheet board on the USB. The Parasheet is the electrical heart of the Cardio Charge (Glow and Flow) Recumbent Bike and is what manages the electricity produced from the equipment. This should rarely need visiting, but in the event it does, TGOCC have provided some basic instructions (below) on how to access it.

The USB is what TGOCC call a consumable item and therefore not warranted by TGO. However, it is a low cost product and is simple to replace.

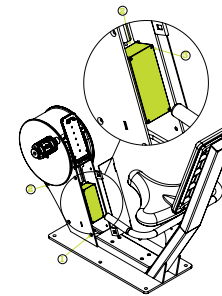

- 1 Remove the four (4) M6 CSunk Pin Torx Screws from the side of the pedal support, to release the rear clad. Place this clad and flange to one side.
- 2 The Parasheet will be bolted in a vertically standing position as shown in the diagram. To remove the parasheet fully you will need to unscrew the two (2) M6 flange screws from the rear of the Parasheet box.
- 3 In order to access the electronics, the Parasheet box lid must be removed, by unscrewing the four (4) M6 CSK Pin Torx screws and two (2) M6 CSK Pin Torx screws that hold the lid to the top clad.
- 4 In order to access the electronics, the Parasheet box lid must be removed, by unscrewing the four (4) M6 CSK Pin Torx screws and two (2) M6 CSK Pin Torx screws that hold the lid to the top clad.

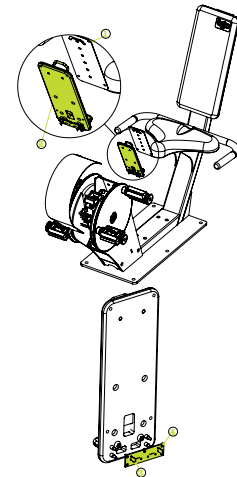

- 1 Remove the stainless steel graphic plate from the console. Use the four (4) Hex Button Pin Torx screws. Retain the screws and put the graphics plate to one side.
- 2 Remove the four (4) now exposed M6x0 CSK Pin Torx Screws which hold the console to the cross trainer frame. Retain the flange in a safe place.
- 3 To remove the USB, unplug the two quad connector ports. Remove the four (4) M6 Nuts and washers, and slide the USB board off the M6 inserts.
- 4 Reapply the new USB board and reverse the above steps to reapply the console.

NOTE 1: Take care as to not damage the casing as the console is pulled away from the cross Trainer.

NOTE 2: Take care as to not damage the casing as the console is pulled away from the cross Trainer.

NOTE 3: The lid screws should be torqued to 5-10Nm in order to retain the IP rating.

4 Reverse Procedure to reassemble.

# TGO aftersales service

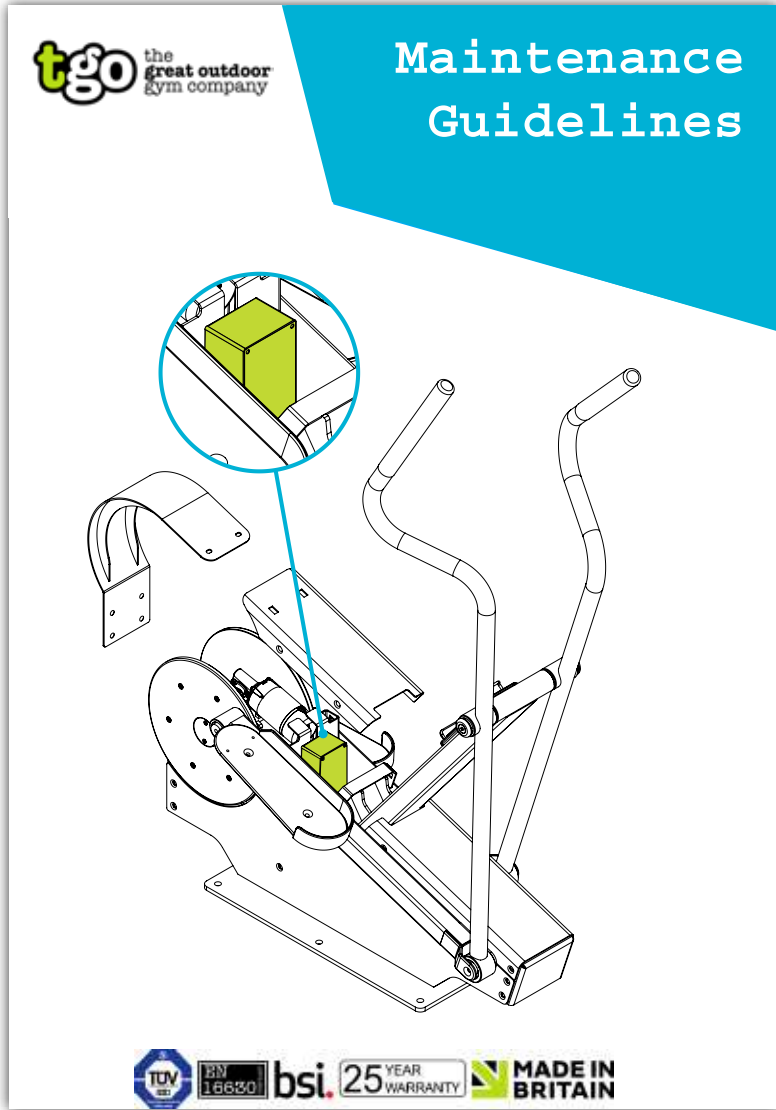

## Maintenance

TGO has been ploughing care into its designs over the past 8 years, ever improving its offer and eradicating known issues. TGO is always aiming for a maintenance free product. However it is important to care for your new gym to ensure it stays in good and safe working order.

TGO is prepared to wrap in maintenance if a number of gyms are purchased.....

## Our promise for your gym aftercare

- Provide you with all the necessary tools to keep your gym in great condition
- Provide you with support and training
- Ensure all consumable elements are available to you in under 72 hours
- Provide you with great warranties
- If a part should break under warranty we will supply a replacement or a fix without any quarms within 4 weeks







**tgo** the gym outdoors

**Kalos Sthenos Rig**

High Pull Up Bar  
Handstand Bar  
Push Up Bar  
Squat Rack

Use Pull Up Bar  
Use Push Up Bar  
Use Squat Rack

Scan for more info about this rig



Thank you for taking the time to read through this document.

**We do hope that you choose British design, innovation and manufacturing.**

**Sustainable Wellness**

Activate your community

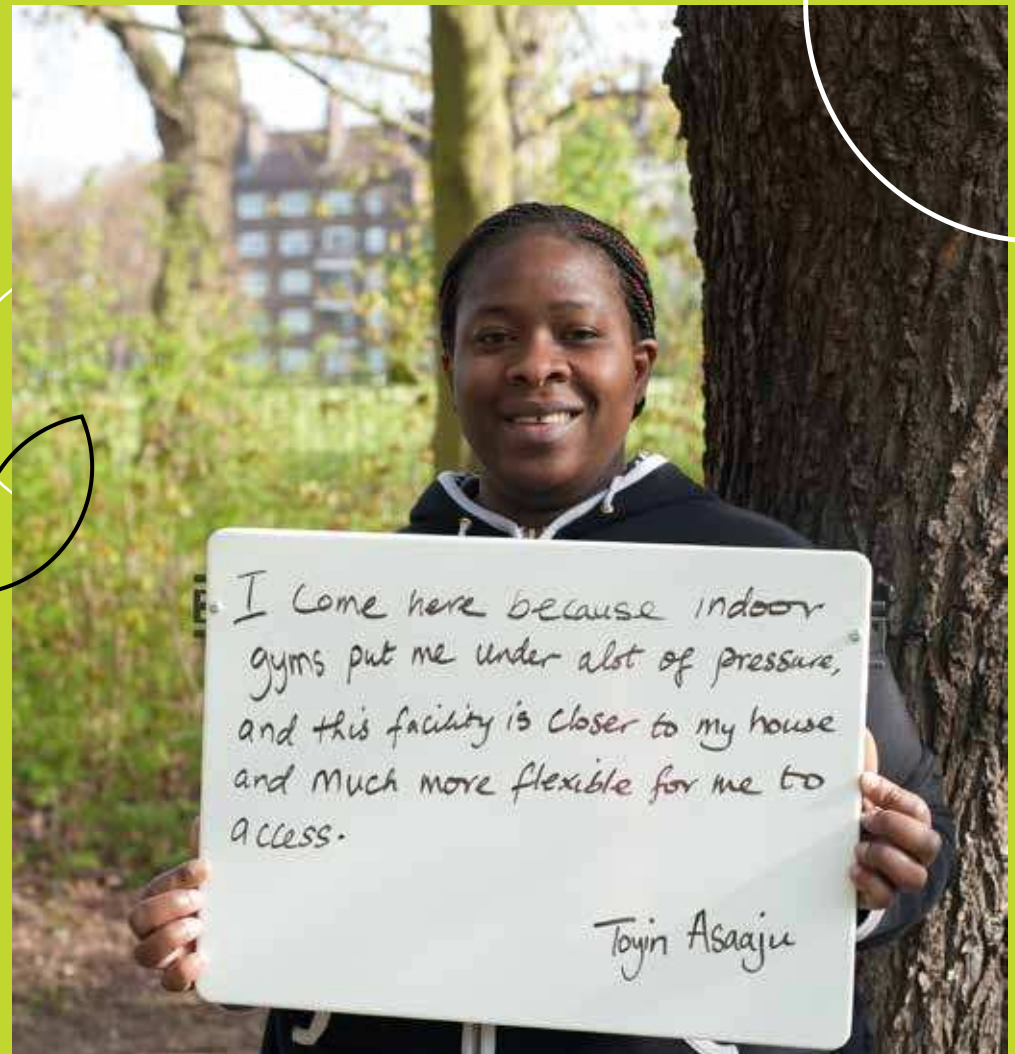

**TERMS & CONDITIONS of TRADING**  
**THE GREAT OUTDOOR GYM COMPANY LTD**  
Edition: 29<sup>th</sup> September 2023

**1. DEFINITIONS**

**Business Day:** A day (other than a Saturday Sunday or Public Holiday) when banks in London are open for business.  
**Conditions:** The Terms & Conditions set out in this document as amended from time to time.  
**TGO:** The Great Outdoor Gym Company Ltd registered in England and Wales with Company Number: 6041524.  
**Contract:** The Contract between TGO and the Customer for the sale and purchase of the goods or the sale and purchase and installation of the goods in accordance with these Conditions.  
**Customer:** The person, firm, corporate body or public sector authority who purchases the goods from TGO.  
**Force Majeure Event:** An event of circumstance beyond the party's reasonable control.  
**Goods:** The Goods (or any part of them) set out in the order.  
**Order:** The Customer's Order for the Goods as set out in the Customer's purchase order form or the Customer's written acceptance of TGO's quotation.  
**Specifications:** Any Specification for the Goods including any related plans and drawings provided by TGO.

**2. INTERPRETATION**

- (a) A reference to a statute or statutory provision is a reference to such statute or provision as amended or re-enacted. A reference to a statute or statutory provision includes any subordinate legislation made under that statute or statutory provision as amended or re-enacted.
- (b) Any phrase introduced by the terms **including, include, in particular** or any similar expression shall be construed as illustrative and shall not limit the sense of the words preceding those terms.
- (c) A reference to **writing, written** or includes emails.

**3. BASIS OF CONTRACT**

- 3.1 These conditions apply to the Contract to the exclusion of any other terms that the Customer seeks to impose or incorporate, or which are implied by trade, custom, practice or course of dealing.
- 3.2 The Order constitutes an offer by the Customer to purchase the Goods in accordance with these Conditions. The Customer is responsible for ensuring that the terms of the Order are complete and accurate.
- 3.3 The Order shall only be deemed to be accepted when TGO issues an acknowledgement of order at which point the Contract shall come into existence.
- 3.4 The Customer waives any right it might otherwise have to rely upon any terms endorsed upon, delivered with or contained in any documents of the Customer that is inconsistent with these Conditions.
- 3.5 Any samples, drawings, descriptive matter or advertising produced by TGO and any descriptions or illustrations contained in TGO's catalogues or brochures are produced for the sole purpose of giving an approximate idea of the goods referred to in them. They shall not form part of the Contract nor have any contractual force.
- 3.6 A quotation for the Goods given by TGO shall not constitute an offer. A quotation shall only be valid for a period of 20 business days from its date of issue.

**4. GOODS**

- 4.1 The Goods are described in TGO's catalogue as modified by any item or change specified in the quotation produced by TGO.
- 4.2 TGO reserves the right to amend the Specification of the Goods if required by any applicable statutory or regulatory requirements.

**5. DELIVERY**

- 5.1 TGO supplies its Goods on an ex works basis. The Customer shall collect the Goods from TGO's manufacturer's premises or such other location as may be advised by TGO prior to collection within 3 business days of TGO notifying the Customer that the Goods are ready.
- 5.2 Delivery is completed on the completion of loading of the Goods at the collection location.
- 5.3 Any dates quoted for delivery are approximate only and the time of delivery is not of the essence. TGO shall not be liable for any delay in delivery of the Goods that is caused by a Force Majeure Event or the Customer's failure to provide TGO with any instructions that are relevant to the supply of the Goods.
- 5.4 If TGO fails to deliver the Goods its liability shall be limited to the costs and expenses incurred by the customer in obtaining replacement Goods of similar description and quality in the cheapest market available, less the price of the Goods. TGO shall have no liability for any failure to deliver the Goods to the extent that such failure is caused by a Force Majeure Event or the Customer's failure to provide TGO with adequate instructions which are relevant to the supply of the Goods.
- 5.5 If the Customer fails to collect the Goods within 3 business days of TGO notifying the Customer that the Goods are ready, then, except where such failure or delay is caused by a Force Majeure Event or TGO's failure to comply with its obligations under the Contract:
  - (a) Delivery of the Goods shall be deemed to have been completed at 9.00am on the third business day after the day on which TGO notified the Customer that the Goods were ready; and
  - (b) TGO shall store the Goods until collection takes place and charge the Customer for all related costs and expenses
- 5.6 If 15 business days after the day on which TGO notified the Customer that the Goods were ready for collection and the Customer has not made collection of the Goods TGO may resell or otherwise dispose of part or all of the Goods and after deducting reasonable storage and selling costs account to the Customer for any excess over the price of the Goods or charge the Customer for any shortfall below the price of the Goods.
- 5.7 TGO may deliver the goods by up to 3 instalments which shall be invoiced and paid for separately. Any delay in delivery or defect in an instalment shall not entitle the customer to cancel any other instalment.
- 5.8 In the event of any of the Goods collected by the Customer being damaged the Customer must report that damage to TGO on the same day as collection.

5.9 In the event of TGO agreeing to deliver the Goods to the Customer and in the event of those Goods being found to be damaged the Customer must report the damage to TGO on the same day as delivery to the Customer.

5.10 If the Customer fails to report damage as required by Clauses 5.8 and 5.9 TGO shall not be liable to the Customer for any loss arising from the damage.

**6. QUALITY**

- 6.1 TGO warrants that on delivery and for a period of 12 months from the date of delivery (**warranty period**) the Goods shall:
  - (a) Conform in all material respects with their description; and
  - (b) be free from material defects in design material and workmanship; and
- 6.2 TGO further warrants components of its Goods:
  - 25 YEAR WARRANTY** on the structural integrity of steel posts, all welds, bars and steel structural equipment.
  - 10 YEAR WARRANTY** against significant corrosion on galvanised products, which are erected at least 250m from the coastline.
  - 5 YEAR WARRANTY** on galvanised products, which are situated within 250m of the coastline.
- 5 YEAR PAINT WARRANTY** for paintwork against material fade from exposure to ultra violet light.
- 5 YEAR WARRANTY** on green energy gym electronics excluding batteries and USB ports.
- 2 YEAR WARRANTY** on bearings and bearing cases.
- 2 YEAR WARRANTY** on plastic or composite parts, seats and fittings and clamps.
- Rubber handles, USB ports, batteries and polyurethane traveler wheels are not covered by warranty but should be replaced during maintenance if required.
- The warranties given in 6.1 and 6.2 above are made upon the following conditions:
  - 6.3
    - (a) The Warranty begins from the date of dispatch from the TGO warehouse.
    - (b) Customers must satisfy themselves that they can carry out the maintenance instructions proficiently using adequately trained engineers.
    - (c) These warranties do not cover installation faults. Customers must satisfy themselves that installations have been carried out in accordance with the installation instructions specified by TGO.
    - (d) TGO shall replace faulty products by sending the replacement part to a designated warehouse. TGO shall pay for posting and packaging. The customer may be required to return the faulty part within 30 days at their own cost.
    - (e) The Customer must pay for the labour cost of the maintenance engineer to carry out all works necessary to diagnose, extract the faulty part, leave the site safe and reinstall safely the replacement part.
    - (f) The Customer shall assess the risk of the site pending repair or during repair to ensure that there is no risk to the health and safety of the general public.
    - (g) In the event of the Customer or appointed maintenance contractor not carrying out its maintenance obligations as set out in TGO's maintenance instructions published from time to time by TGO on its website or in writing these warranties shall be null and void. TGO shall be entitled to request to see the Customer's maintenance log books from time to time with the names, dates and signatures of engineers.
    - (h) Non galvanised product must not be situated within 1km of the coast.
    - (i) The warranties do not cover damage caused by accident, negligence, normal wear and tear, failure to maintain or misuse.
    - (j) The Customer must report all warranty claims within 14 days. The report to TGO must include correct name of product, installation date, a photo of the manufacturing label, photographic evidence and clear description of issues.
    - (k) The Customer may assign the benefit of the guarantee to a purchaser of or a successor of title to the gym equipment provided that the Customer sends within 4 weeks of the assignment a copy of the same to TGO plus a fee of £75 plus vat.
    - (l) TGO shall not be liable for any consequential loss or damage arising from the failure of the equipment other than for loss or damage which arise from personal injury or death for which no limit on liability is placed.
    - (m) The warranties do not cover consumable items.
  - 6.4 Except as provided in this clause TGO shall have no liability to the Customer in respect of the Goods failure to comply with the warranty set out in Clause 6.1.
  - 6.5 The terms implied by Sections 13 to 15 of the Sale of Goods Act 1979 are, to the fullest extent permitted by law, excluded from the Contract.
  - 6.6 The Conditions shall apply to any repaired or replacements Goods supplied by TGO.
  - 6.7 The TGO Warranties do not apply to branded goods bought in from other manufacturers to fill the customer's order. The liability of TGO in relation to those goods is limited to the warranty provided by those manufacturers.
  - 6.8 No warranty against corrosion is given for any product galvanised or not which is in direct and regular contact with chlorinated water salt water or salt spray.

**7. SAFETY**

- 7.1 Customers must ensure that all Goods purchased from TGO are installed by competent workmen using high quality materials and in accordance with Standard EN16630.
- 7.2 Immediately following the installation of the Goods referred to above the Customer must arrange for the installation to be inspected by a Registered Play Inspector and obtain a certificate that the installation is safe and has been made in accordance with Standard EN16630 and TGO's installation manual.
- 7.3 In the event of any fault occurring in any of the Goods the Customer shall take out of service to the public the product to which the fault relates until the faulty product has been repaired/replaced.
- 7.4 TGO shall be entitled to send to the customer product defect warnings and in the event of the Customer receiving any such warning the Customer shall act on the recommendations of TGO incorporated within the product warning so as to ensure that there is no risk of the fault becoming a risk to safety.
- 7.5 TGO shall be entitled to require the Customer to change the signage relating to any of the Goods and in the event of this right being exercised by TGO the replacement signage shall be provided free of charge.

**8. TITLE AND RISK**

- 8.1 The risk in the Goods shall pass to the Customer on collection.
- 8.2 Title to the Goods shall not pass to the Customer until the earlier of:
  - (a) TGO receives payment in full for the Goods and
  - (b) The Customer resells the Goods in which case the title to the Goods shall pass to the Customers immediately before that resale has taken place.

t: 01795 373301 e: enquiries@tgogc.com w: www.tgogc.com

The Great Outdoor Gym Company is a trading name of The Great Outdoor Gym Company Ltd. Incorporated in England and Wales under company no: 6041524  
Registered address: 2 Jubilee Way, Faversham, Kent ME13 8GD, UK

**tgo** the great outdoor gym company

t: 01795 373301 e: enquiries@tgogc.com w: www.tgogc.com

The Great Outdoor Gym Company is a trading name of The Great Outdoor Gym Company Ltd. Incorporated in England and Wales under company no: 6041524  
Registered address: 2 Jubilee Way, Faversham, Kent ME13 8GD, UK





## 9 PRICE AND PAYMENT

- 9.1 The price of the Goods shall be the price set out in the Order
- 9.2 The price of the Goods;
- (a) Excludes amounts in respect of Value Added Tax (VAT) which the customer shall additionally be liable to pay to TGO at the prevailing rate, subject to the receipt of a valid VAT invoice and
- (b) Excludes the costs and charges of packaging insurance and transport of the Goods.
- 9.3 The Customer shall pay a 25% deposit of the price of the Goods in full within 30 days of the date of the invoice. Payment shall be made to the bank account nominated in writing by TGO.
- 9.4 The Customer shall pay the 75% balance invoice in full within 30 days of the date of the invoice. Payment shall be made to the bank account nominated in writing by TGO.
- 9.5 If the Customer is based outside of the UK 100% of the price of the Goods will be required to be paid in full at point of placing order.
- 9.6 If the Customer fails to make any payment due to TGO under the Contract by the due date for payment then the Customer shall pay interest on the overdue amount at the rate of 10% per annum. Such interest shall accrue on a daily basis from the due date until actual payment of the overdue amount, whether before or after judgement. The Customer shall pay the interest together with the overdue amount.
- 9.7 The Customer shall pay all amounts due under the contract in full without any set-off, counterclaim, deduction or withholding (except for any deduction or withholding required by law). TGO may at any time without limiting any other rights or remedies it may have, set off any amount owing to it by the customer against any amount payable by TGO to the Customer.
- 9.8 In the event of the Customer cancelling the order made by the Customer and that cancellation is received by TGO before the Goods have been delivered by TGO to the Customer or collected by the Customer the Customer shall pay to TGO by way of liquidated and ascertained damages 50% of the price of the Goods within 14 days from the date of cancellation.
- 9.9 In the event of the Customer cancelling the order made by the Customer after the Goods have been delivered by TGO to the Customer or collected by the Customer the Customer shall pay to TGO 100% of the price within 28 days from delivery of the Goods to the Customer or collection of the Goods by the Customer.
- 9.10 We will at no time notify a customer of a bank account change by e-mail. Customers are required to confirm payment banks details by telephone before payment is made.

## 10 INSTALLATION

- 10.1 This entire clause shall only apply to Contracts where TGO has agreed with the customer to install TGO Goods at a site nominated by the Customer.
- 10.2 In the event that this clause does apply and it then being found that there is a conflict between this clause and other clauses in these Terms and Conditions the provision made under this clause shall prevail.
- 10.3 The Customer shall obtain prior to commencement of the installation all necessary Consents statutory or otherwise required for the works of installation.
- 10.4 TGO will execute the works of installation using good and sound materials and in a proper and workmanlike manner.
- 10.5 The customer shall pay to TGO the price of the Goods and installation 30 days from the date of practical completion.
- 10.6 TGO shall certify the date of practical completion.
- 10.7 The risk in the Goods shall vest in the Customer as from the date of practical completion and the Public Liability risk in the installation as a whole shall vest in the Customer as from the date of practical completion.
- 10.8 The customer warrants that the ground conditions for the intended installation contain no special adverse properties or features. Should it be discovered that the Customer's site does have adverse properties or features TGO's surveyor shall define those adverse properties or features and the cost of overcoming the same so that the installation may proceed.
- 10.9 TGO will provide the customer with a copy of the report from the surveyor. The Customer will have 10 days in which to accept the report and pay for the additional works, or terminate the Contract by paying 25% of the contract Price in compensation.
- 10.10 In the event of the Customer electing to terminate the contract pursuant to clause 9.9 above the property in the Goods will remain with TGO and not with the Customer.

## 11 TERMINATION

- 11.1 Without limiting its other rights or remedies, TGO may terminate the Contract with immediate effect by giving a written notice to the Customer if:
- (a) The Customer commits a material breach of any term of the Contract and (if such a breach is remediable) fails to remedy that breach within 10 Business Days of that party being notified to do so;
- (b) The Customer takes any step or action in connection with its entering administration, provisional liquidation or any composition or arrangement with its creditors (other than in relation to a solvent restructuring), being wound up (whether voluntarily or by Order of the Court, unless for the purpose of a solvent restructuring), having a receiver appointed to any of its assets or ceasing to carry on business.
- (c) The Customer suspends, threatens to suspend, ceases or threatens to cease to carry on all or a substantial part of its business or
- (d) The Customer's financial position deteriorates to such an extent that in TGO's opinion the Customer's capability to adequately fulfil its obligations under the Contract have been placed in jeopardy.
- 11.2 Without limiting its other rights or remedies, TGO may suspend provision of the Goods under any Contract it may have with the Customer if the Customer becomes subject to any of the events listed in clause 11.1(a) to Clause 11.1(d) or TGO reasonably believes that the Customer is about to become subject to any of them or if the Customer fails to pay any amount due under the contract on the due date for payment.
- 11.3 On termination of the contract for any reason the Customer shall immediately pay to TGO all of TGO's outstanding unpaid invoices and interest.

## 12 LIMITATION OF LIABILITY

- 12.1 nothing in these conditions shall limit or exclude TGO's liability for:
- (a) Death or personal injury caused by its negligence or the negligence of its employees, agents or sub-contractors
- (b) Fraud or fraudulent misrepresentation.
- (c) Breach of the terms implied by Section 12 of the Sale of Goods Act 1979 or

- (d) Defective products under the Consumer Protection Act 1987 or
- (e) Any matter in respect of which it would be unlawful for TGO to exclude or restrict liability.
- 12.2 Subject to Clause 11.1:
- (a) TGO shall under no circumstances whatsoever be liable to the Customer, whether in Contract, tort (including negligence), breach of statutory duty, or otherwise, for any loss of profit on any indirect or consequential loss arising under or in connection with the Contract and
- (b) TGO's total liability to the Customer in respect of all other losses arising under or in connection with the Contract whether in Contract, tort (including negligence), breach of duty, or otherwise, shall in no circumstances exceed 150% of the price of the Goods.
- 13 **FORCE MAJEURE**  
Neither party shall be in breach of contract nor liable for delay in performing, or failing to perform, any of its obligations under the Contract if such delay of failure result from a Force Majeure Event. If the period of delay or non-performance continues for 13 weeks then either party may terminate the Contract by giving 2 weeks written notice to the other.
- 14 **GENERAL**
- 14.1 **Assignment and other dealings.**
- (a) TGO may at any time assign, transfer, mortgage, charge, sub-contract or deal in any manner with all or any of its rights or obligations under the contract.
- (b) The Customer may not assign, transfer, mortgage, charge, sub-contract, declare a trust over or deal in any other manner with any or all of its rights or obligations under the contract without the prior written consent of TGO.
- 14.2 **Entire Agreement.**
- (a) The Contract constitutes the entire agreement between the parties and supersedes and extinguishes all previous agreements, promises, assurances, warranties, representations and understandings between them, whether written or oral, relating to its subject matter.
- (b) Each party agrees that it shall have no remedies in respect of any statement, representation, assurance or warranty (whether made innocently or negligently) that is not set out in this agreement.
- 14.3 **Variations**  
No variation of the Contract shall be effective unless it is in writing and signed by a director of TGO or an authorised representative of the Customer
- 14.4 **Severance**  
If any provision or part-provision of the Contract is or becomes invalid, illegal or unenforceable, it shall be deemed modified to the minimum extent necessary to make it valid, legal and enforceable. If such modification is not possible, the relevant provision or part-provision shall be deemed deleted. Any modification to or deletion of a provision or part-provision under this clause shall not affect the validity or enforceability of the rest of the Contract.
- 14.5 **Notices**
- (a) Any notice or other communication given to a party under or in connection with the Contract shall be in writing addressed to its principle place of business or such other address as that party may have specified to the other in writing in accordance with this clause and shall be delivered personally, sent by pre-paid 1<sup>st</sup> Class post or other next working day delivery service, commercial courier, or email.
- (b) The provisions of this clause shall not apply to the service of any proceedings or other documents in any legal action.
- 14.6 **Third Party Rights**  
No one other than a party to this Contract and their permitted assignees shall have any right to enforce any of its terms.
- 14.7 **Governing Law**  
The contract and any dispute or claim arising out of or in connection with it or its subject or formation shall be governed by and construed in accordance with the law of England and Wales.
- 14.8 **Jurisdiction**  
Each party irrevocably agrees that the Courts of England and Wales shall have exclusive jurisdiction to settle any dispute or claim arising out of or in connection with the Contract or its subject matter or formation.



MADE IN  
BRITAIN



# World class outdoor gyms activating your local community

.....  
**Uniquely made in Britain**

.....  
**Outdoor Gym Concept Presentation**  
Addington Parish Council





# Introduction & Executive Summary

## Thank you!

We are delighted to present our visions and designs for the outdoor gym for Addington Parish Council.

Our vision is to create gyms that help communities become healthier and more sustainable. **Healthy People, Healthy Planet.**

We have installed over 2000 outdoor gyms worldwide which provide a sustainable inclusive way to unlock the power of movement. Movement is a wonder drug to prevent lifestyle diseases. At TGO gyms we can also recycle your workout to create electricity!

All our designs have been created through our 15 years' experience in developing outdoor gym solutions across the UK. We pride ourselves in working closely with our customers to develop inclusive outdoor gym spaces that encourage communities to be stronger, together.

Watch our vision [here](#)



# ➤ **Addington Parish Council** ➤

## Gym Proposal

.....



TAKING THE INDOOR GYM OUTSIDE

An amazing gym for people new to exercise as well as athletes.





# Gym Equipment - Addington Parish Council

.....

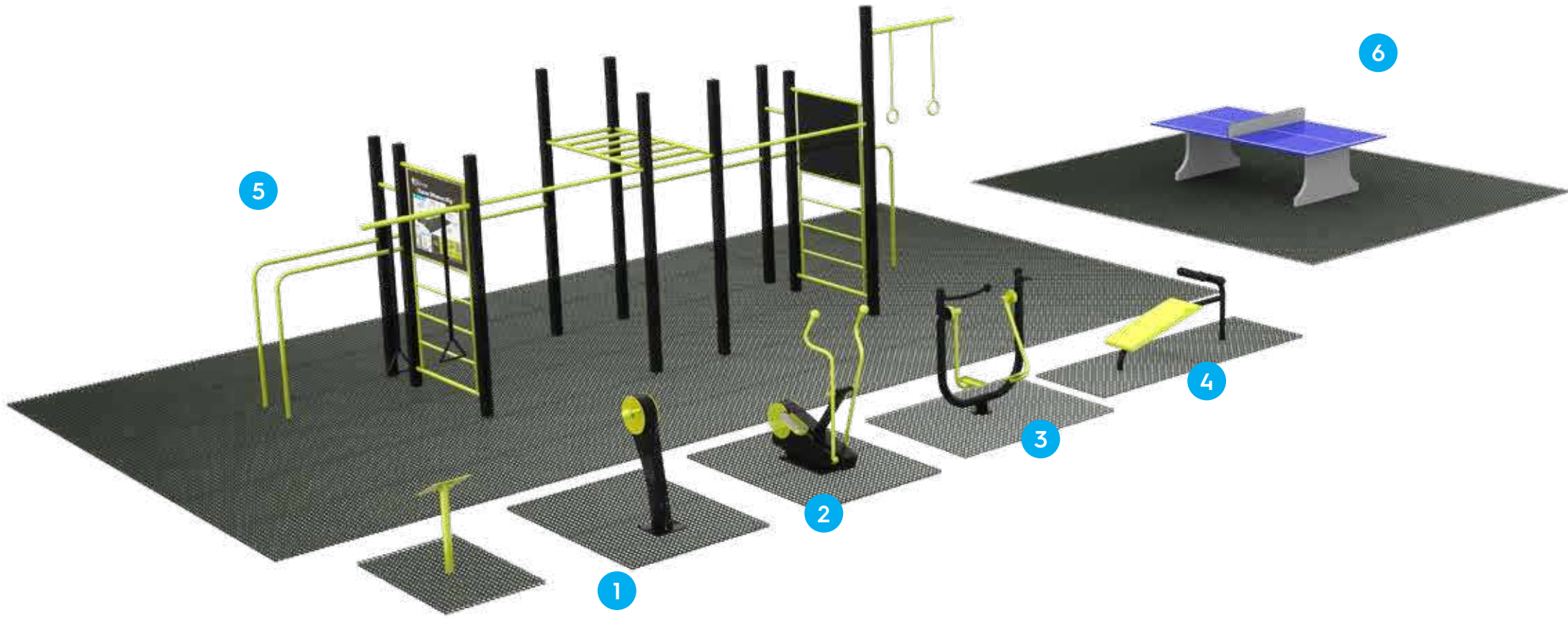

- Gym Equipment:**
- |                  |                        |
|------------------|------------------------|
| 1. Hand Bike     | 4. Single Sit Up Bench |
| 2. Cross Trainer | 5. Kalos Sthensos Rig  |
| 3. Air Walker    | 6. Table Tennis        |



# Gym Equipment - Addington Parish Council

## 1. FS907 Hand Bike

All TGO products are designed to be as inclusive as possible but the Hand Bike is one of TGO's star pieces for inclusivity. This piece can be used by both able bodied users and wheelchair users. It is an excellent cardiovascular piece of equipment, toning up arms and shoulders whilst improving strength, stamina and endurance.



## 2. FS861 Cross Trainer

On this stylish cross trainer, the user will get a cardiovascular workout, as well as helping to improve muscle tone in the legs, arms and core. With top quality bearings and sliding mechanisms the TGO cross trainer is smooth, safe and easy to use. From super fit to those new to exercise, this is the perfect piece for any gym. Over the years this has proven to be one of our most popular pieces.



## 3. FS031 Air Walker

Air Walker in your outdoor gym, you will be able to increase your strength and cardio fitness, get a low-impact total body toning workout and ultimately lose weight.



## 4. FS100 Single Sit Up

The Bench has a number of exercise variations on this piece of equipment not just limited to sit ups. The bench also enables the user to perform incline press ups and tricep dips and the bench caters for a wide variety of sit up and abdominal crunch exercises.



## 5. Kalos Sthenous Championship Rig

Designed with **calisthenic** athletes and event organisers, this rig can support your **community** into a lifestyle of bodyweight exercises whilst building community.

- 8m x 2m
- Championship specification bar sizes and selection and layout
- 2 Parallel bars
- 4 ultra wide pull up bars (2m each)
- 2 x Olympic ring brackets
- Wide monkey bars
- 2 x Swedish rails up to 1.2m then handstand boards above
- Signage with instructions and digital support
- **Female friendly** spec



# Gym Equipment - Addington Parish Council

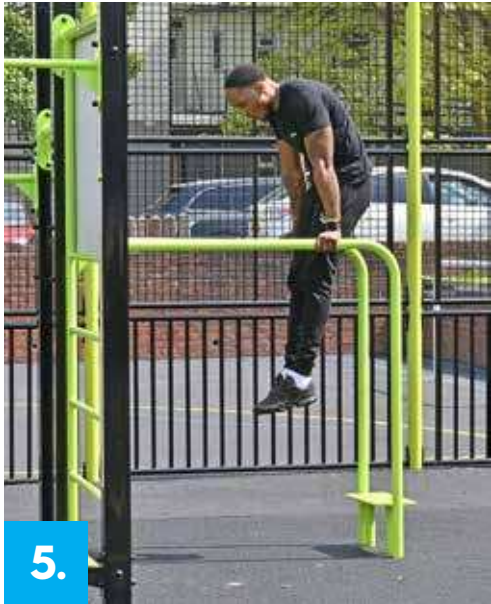
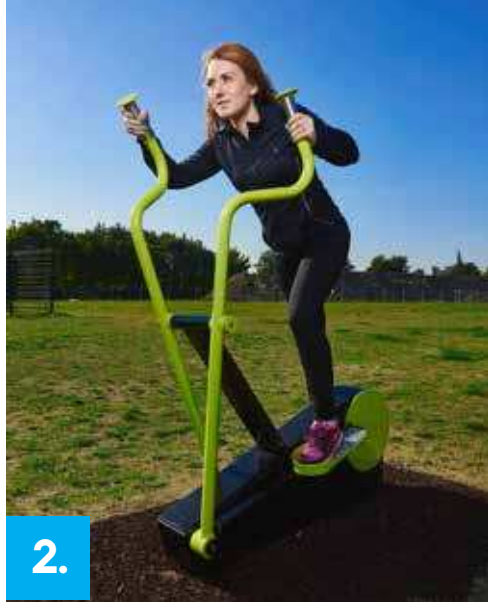
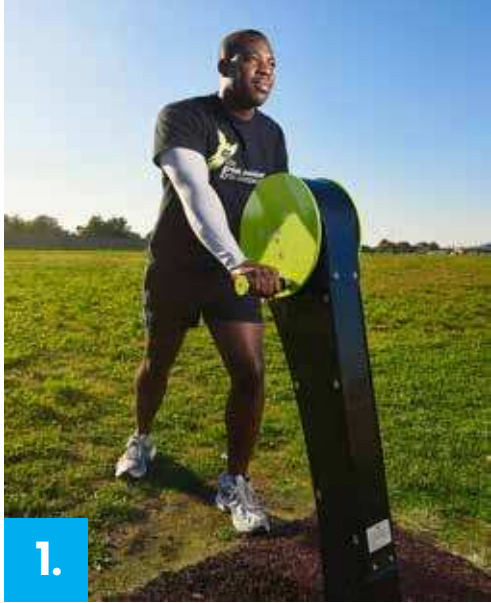



# Upgrade your Gym Smart Activator Screen

.....

The Great Outdoor Gym Company (TGO) is introducing another world first in its sector – Smart activator screens. These free classes delivered at TGO gyms on smart screens are community friendly and compliment the gym and park space. The solution offers communities the ability to access a wide range of classes, multiple times a day. The wider access brings the group size down making the solution safer for everyone. Every class has options off the gym so that all TGO gyms work with the smart screen.

Classes available - <http://www.tgo-activate.com/>



# Our Story

The TGO group consists of two sister companies, The Great Outdoor Gym Company (TGO) which is the equipment company and TGO activate, the activation and digital platform arm. Formed in 2007, The Great Outdoor Gym Company (TGO) is the worldwide pioneer in safer, energy generating, inclusive outdoor gyms, installing in excess of **2000 sites** so far globally. **Made in Britain**, TGO has always done the right thing by **quality, safety** and **innovation**. TGO designs, supplies, installs and maintains outdoor gyms.

**TGO is also an export champion** for The Department of International Trade (DIT) and our gyms can be found in every corner of the globe from Jumeirah Beach in Dubai, to Randwick Sydney Coastal Walk in Australia, Metro plaza Hong Kong, and Gardens by the Bay Singapore. These sites alone have around 50 millions of visitors per year. It is estimated that 60 million people come across and interact with TGO gyms each year.



Scan to find out



TGO deliver 70 x Olympic branded gyms for Adidas



TGO invent gyms that generate electricity and a human energy storage system (EDU)



2007

2008  
2012

2009

2012

2012  
2017



TGO Gym incorporate



TGO move manufacturing to the UK



TGO lands in Dubai, Sydney, Singapore, Hong Kong... and many more





TGO's energy gyms are featured at Paris Climate change conference

2015



Develop Smart data

2016



2017



TGO pioneer free classes

2018



Founder of TGO, Georgie Delaney is awarded an MBE

2020

2021

2022

**Proud** to be 100% manufactured in Britain, TGO is a British success story. Behind TGO and TGO activate is a dynamic and experienced team that have achieved a huge amount. At the heart of TGO are values of care, doing the right thing and vision.

The business has grown over the past 15 years but it is still a family run business with Matt Delaney (former Sport England Director) and Georgie Delaney who in 2021, was honoured with an MBE for her work in trade and export.



Commissioned by the UN as a legacy project of COP22



TGO creates a gym out of recycled aerosol cans for Right Guard



Kevin McCloud picks TGO again as one of his all-time favourite Green Heroes



Over 2000 gyms installed and new vision of healthy people and healthy planet....

# Our Credentials

.....

**Proud to still be a family operated business**

**Proud to uniquely manufacture in the UK**

**Proud to have 2000 successful gym installations worldwide**

We wish to make it clear that through every phase of the process, it is our intention to develop a close working relationship with you.

Together, we will co-create success in your outdoor gyms and for our respective businesses. We understand that the only way to achieve outstanding results is to inbed a culture of quality in every aspect of the delivery process, including:

- ✓ Expert project delivery and ongoing account management
- ✓ Inclusive equipment designed for all abilities
- ✓ Approachable, progressive and inclusive design and equipment layout
- ✓ World leading equipment, designed and manufactured in the United Kingdom

*In order to deliver the most cost-effective solution, the entire contract will be priced and delivered with best value.*



# What our customers say



"I've worked with TGO over a number of years on a number of projects and I know their service is second to none. The impact that this activity zone has had has already been beyond belief because there is something for everyone."

**Lisa Dodd-Mayne, Director of Sport and Active Communities, University of Warwick**



"The green gyms have been a major success with residents. Their popularity is due to the enormous effort of TGO and the council, working together with local people to identify the very best equipment for their needs. The quality of the equipment is exceptional too."

**Alison Hibbert, Leisure Services Manger at Slough Borough Council**





# Innovators and leaders in outdoor gyms

TGO was specialising in outdoor gyms before all other UK companies. Our ethos is to do the right thing in safety, quality, functionality, and inclusivity. We have led the industry in all these areas and for that reason the BSI approached us initially prior to the creation of the European standard.

- 1 Leaders on **QUALITY** - British made, and designed products
- 2 Leaders in the industry of outdoor fitness **SAFETY** worldwide
- 3 Leaders for best **INNOVATIVE DESIGNS** and most comprehensive Calisthenics (Street Workout) range
- 4 Leaders in **INCLUSIVE** equipment for all abilities and progression including wheelchair users
- 5 Leaders in **SUSTAINABILITY** by planting trees and generating people power!

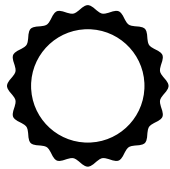

Designed by health and fitness professionals



Made in Britain



Safer



Inclusive



Generates electricity and it's even Smart



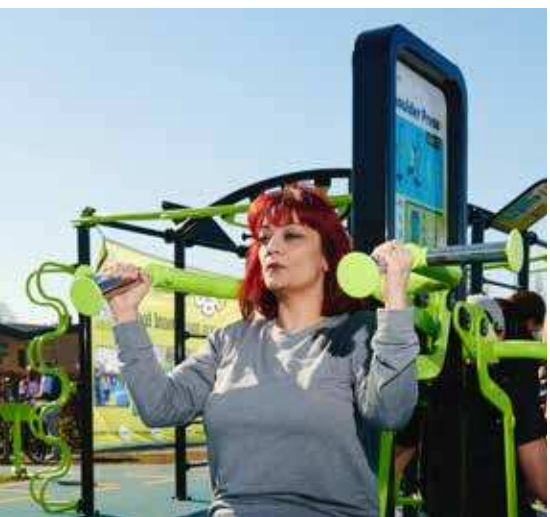
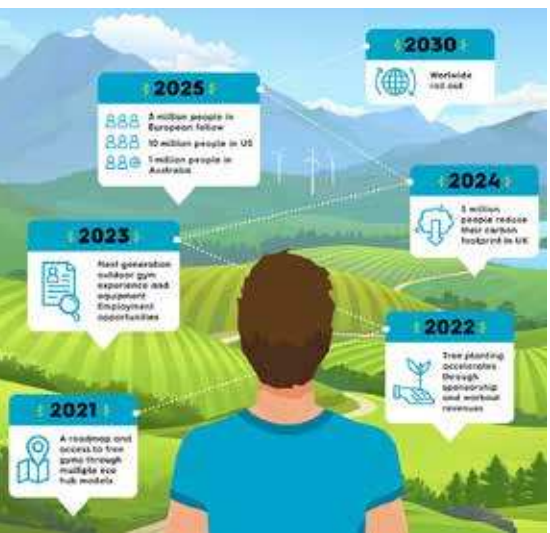



# Experience

.....

We are a British manufacturer of outdoor gyms that export worldwide. We are recognised by the Department of International Trade as an Export Champion and GREAT British brand. We've worked with Rolls Royce, adidas, United Nations and the hundreds top parks, universities and schools worldwide.

Over the past 15 years, we've installed 2000 gyms and every year, we innovate and develop our range. We have SMART gyms that generate power for phone charging, variable resistance, and digital interaction via our app. With the best calisthenics & weights range available on the market. Our gym service is known to be very responsive, and our experienced team are always friendly and available.







# TGO gyms of the future vision

# Executive Summary

---

- ✓ Provide outdoor gym layouts that meet the budgets and will help you achieve its corporate objectives
- ✓ Deliver and install world leading outdoor fitness equipment that is manufactured in the UK with quality and durability designed in from the outset
- ✓ Exciting, engaging outdoor gym designs that will delight the community
- ✓ User familiarisation through the consistency of equipment types
- ✓ Equipment and flooring layouts that are both accessible, approachable, in-line with current fitness trends, provide floor space and will attract more users onto the gyms
- ✓ Timely project management with clear communications between our two companies from contract award
- ✓ To deliver quality in every aspect of the contract while adding value and working within the budgets stated





# Why choose a TGO gym?



Designed by  
health and fitness  
professionals



Made in  
Britain



Safer



Inclusive



Generates  
electricity and  
it's even Smart

# What sets TGO apart

.....

- ✓ TGO gyms are safer
- ✓ TGO gyms are stronger
- ✓ TGO gyms are more sustainable
- ✓ TGO gyms are smarter
- ✓ TGO gyms are more inclusive market
- ✓ TGO gyms are more family friendly
- ✓ TGO gyms are activation friendlier
- ✓ TGO gyms cater for all fitness abilities
- ✓ TGO gyms come with the most experience
- ✓ TGO gyms are the best value on the market



Image: Freddie Flintoff and Jamie Redknapp at Queen Elizabeth Olympic Park, Right Guard TGO gym



# Your Gym Signage

- ✓ Signage QR codes link user to TGO Activate App.
- ✓ QR codes on signage to log and track workouts.
- ✓ Signage graphics to display how to use equipment.
- ✓ 'Activate' App enables users to find their TGO gym, log and track workouts and share with friends on social media
- ✓ Educational signage



Click here to download the TGO Activate App



## Shoulder Press

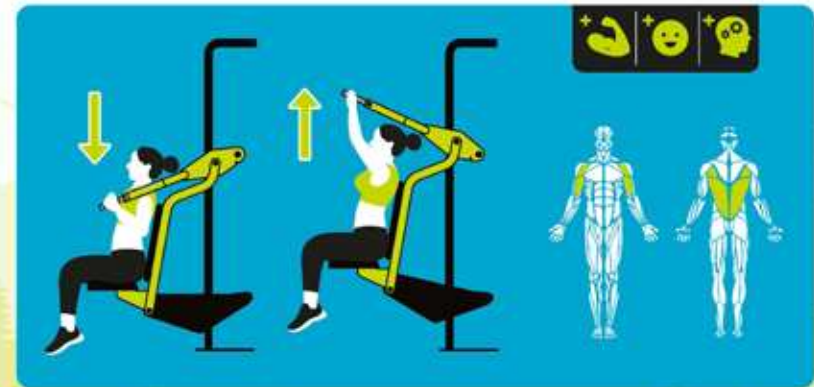

All the signage comes with a QR codes. This QR code enables you Download the TGO Activate app to log your workout and shows you select a video tutorial on that particular piece.

# Your gym is Made in Britain

- ✓ 25 year warranty on structural steel
- ✓ Installed worldwide
- ✓ Load and cyclical testing
- ✓ TGO fixings are anti-vandal and anti-tamper
- ✓ CE marked steel
- ✓ Welds certified to BSEN ISO 15614
- ✓ Built-in resistance to offer great health outcomes



Spinning Bikes in production



Hand Bike in production





# TGO Manufacturing process

.....



1. All TGO equipment is manufactured in our UK factories (one in Gateshead and one in Selby)



2. UK Sourced Materials – 99% of our component part materials is sourced within the UK meaning we have tighter control over our production and supply. Raw materials and parts are bulk ordered with high re-order levels to ensure we are never without stock of materials & parts.



3. Parts Fabrication – we are continually making batches of component parts for our products. Once an order is received it is added to the Production Schedule for parts to be picked and sent to the Paint Shop.



4. Painting Process – all parts are primed and powder coated in house through our paint plant.



5. Assembly – once parts are painted they are assembled to build the products in our Assembly area.



6. Quality Control – at all stages of the manufacture parts are quality checked. The products received a final quality check before they are palletised & wrapped ready for dispatch.

# Your TGO gym is Smart

- ✓ 'Activate' App enables users to find their TGO gym, log and track workouts and share with friends on social media
- ✓ 'Smart' technology in TGO gyms measures hits of gyms
- ✓ 'Smart' gyms come with dashboards for gym owners to measure, engage and sustain usage
- ✓ 'Smart' signage - QR codes on signage to log and track workouts
- ✓ Device holder - to place your device where you can see it charge on cardio charge range



ACTIVATE

All the signage have two QR codes: 1 QR code allows you to log your workout in the Activate App and 1 QR code shows you where you are able to see a video tutorial on that particular piece.





# Your gym is Inclusive

.....

**Every piece has been carefully designed with inclusivity in mind featuring key elements of the IFI standards:**

- ✓ Large font on signage
- ✓ Wider seats and transfer handles
- ✓ Brightly coloured interactive parts
- ✓ Start and finish diagrams
- ✓ Created for communities - with everyone in mind
- ✓ TGO Rig features a variety of bars for additional accessories to be added on, such as tricep and bicep bands



## Transfer handles

To enable people with mobility problems to access equipment safely

## Signage

Start and finish diagrams and large font on signage  
Wider seats to give more comfort to the user

## Resistance gauged to user's own body weight

This helps to ensure that resistance of equipment (such as the and lat pull down/shoulder press) are not too strenuous, meaning people of all abilities can still participate.



Wider seats and transfer handles on the Lat Pull Down/Shoulder Press

# Your gym is Sustainable

.....

At TGO we have a healthy people and healthy planet vision!

- ✓ We recycle human energy with our energy range!
- ✓ We plant 10 trees for every piece of equipment we install and 100 trees for rigs. This ensures the facility is offset.
- ✓ TGO Cardio Charge products charge up smart phones and other devices via USB port or contactless plate.
- ✓ Unique console on every TGO Cardio Charge piece. Includes watt counter that lights up in use for motivational boost and wow factor
- ✓ No need to disturb the groundwork if you want to upgrade as we have designed special bases
- ✓ TGO gyms are made to last - By manufacturing in the UK, we ensure a long lasting product that will stand the test of time. If supplying to the UK, this also means less transportation than our competitors.

TGO have already planted 50k trees with the vision to plant millions more as TGO plant 10 trees for every piece of equipment installed

**We plant a tree for every piece we install!**

in the UK



Kevin McCloud from Grand Designs picks TGO multiply years running as one of his all-time favourite Green Heroes



# We are Sustainable

Our gyms are made from recycled steel and are recyclable. The flooring we use has a sub-base made from recycled tyres. Our gym at the Queen Elizabeth Olympic park was made from recycled aerosol cans and generates power. [Read the full story here](#)

We were invited to show our equipment at **COP21** at the inaugural Paris Climate Change Conference. We were commissioned by the United Nations for **COP22** in Marrakech. We have gym equipment that generates power that can be added to your gym.

**Our vision** for the communities around our gyms to be **healthy and sustainable**. We want to help people go net zero. Our greenest greatest gym chain concept will take people on a journey from unhealthy and unsustainable to healthy, happy and powerful contributors to the planet's restoration. With over 2000 gyms under our belt and gyms that generate power from human energy we are set to unlock the potential of our 15 years to date to save people and planet!

**With your help we can develop a community owned operator model that is profitable for both people and planet.**

We have developed a **people power pledge**.

One of the main thrusts of the gym will be to encourage the wider community to adopt the **people power pledge**.

We can encourage the community to get involved in this campaign. Climate activities can be advertised on your personalised page on our app too as well as yoga and fitness classes.



**Our People Power pledge** consists of 9 suggested pledges to make you more sustainable, starting with your health and wellbeing through to helping reduce your carbon footprint and race to net zero. The 9 F's: Faith not fear, Fitness, Family and friends, Food, Fuel, Forest, Forgiveness, Financial sustainability, Focus on mission.

**Faith not fear:** The key to change is having optimism. We can feel disempowered if we think there is no hope, so the first step on the sustainability journey is optimism of making a difference

**Fitness:** Look after health through movement, community and sustainable diet

**Food:** Switch to plant based (73% reduction in carbon footprint) - TGO UN approved food box

**Fuel:** Switch to renewable energy and earn points by generating power at TGO gyms

**Family:** Influence family to do the same

**Friends:** Influence friends to do the same

**Finances:** bank with an ethical bank

**Forest:** Plant or generate trees

**Focus:** Ensure your work is aligned with the planet's needs and influence your workplace. Or start working on environmental matters.



SCAN TO TAKE THE PEOPLE POWER PLEDGE

# Your gym is Safer

.....

- ✓ TGO equipment is compliant with BS EN16630:2015
- ✓ All TGO stop mechanisms are concealed
- ✓ All moving parts are limited in their movement
- ✓ All moving elements are within the framework of the equipment
- ✓ All TGO equipment is free of crush points, entrapment points, shear-points and sharp edges





# Your gym is Stronger

 **MADE IN  
BRITAIN**

**We're  
Stronger**

.....

We pride ourselves on our quality. We moved our manufacturing back to the UK in 2012 to control the quality, ensure the materials are to spec and ensure the workmanship is to British standards across the TGO range. This gives us a confidence to offer the following warranty:

- ✓ **25 warranty on metalwork**
- ✓ **5 year warranty on paintwork**
- ✓ **2 year warranty on bearings**

- Made in the UK
- Load and cyclical Testing
- TGO fixings are anti-vandal and anti-tamper
- CE marked steel
- Welds certified to BSEN ISO 15614
- All TGO Equipment is E-Coated same technique as car industry



# TGO maintenance and spare parts

## Maintenance requirements

The TGO product range has been designed to require very little maintenance to keep it running smoothly and looking great. However, as many of the pieces have moving parts these will need light maintenance

To keep everything operating as they should this involves some basic daily/weekly/monthly inspections of the equipment, for example, checks for any vandalism or faults, lubrication of moving parts, touching up of any paintwork damage.

We provide you with a 'Light Maintenance Kit' which includes a maintenance manual, correct fixing tools, lubrication oil and touch up paints.



## Spares / replacements

TGO can offer an extensive maintenance pack on substantial orders so that spares that may be required are available from that pack immediately (this will include touch up paint, spare fixtures and fittings, bearings etc). Anything from that pack that is used within the warranty period will be replaced FOC (all our stock and spare parts are all made in the UK so lead time is short and no long shipment delays!)

We will keep a record of the detailed specification of your equipment to ensure the spares for your equipment are available for the duration of the contract.

### The benefit of TGO with spares/ Replacements:

1. We manufacture here in the UK
2. Many of our parts are common to each piece
3. Lead time on common spares will be in most cases under 72 hours if not less.

Spares Kits	Per Product	Partner Pack
Cross Trainer	<ul style="list-style-type: none"> <li>4x MS Cage Nut - For Clad</li> <li>1x Drive Ring - Rear End</li> <li>2x M16x16 Pin Torx CSNYK - Clads</li> <li>2x M16x20 Pin Torx CSNYK - End caps</li> <li>2x M16x40 Pin Torx Hex Underlays CSNYK - Central fix</li> <li>1x M16x16 Pin Torx Button - Rear Clad</li> <li>1x MB Washer - Rear Clad</li> </ul>	<ul style="list-style-type: none"> <li>2x Drive - 117_181_19 FOB - Rear Plank/Handle Pivot</li> <li>1x Drive - 65x44x25-12</li> <li>1x End Cap - TGOGC3-A-03-05</li> <li>1x Fitness Plate - TGOGC23-11</li> </ul>
Hand Bike	<ul style="list-style-type: none"> <li>1x M16x20 Pin Torx CSNYK - Pedal end cap</li> <li>2x M16x16 - Clads</li> <li>1x M16x16 Pin Torx Button Head - Top clad</li> <li>2x M16x20 Pin Torx CSNYK - Clads</li> <li>2x M16x40 Pin Torx Hex CSNYK - Central fix</li> </ul>	<ul style="list-style-type: none"> <li>1x Handle Asm - TGOGC87-A-03</li> <li>1x Handle End Cap - TGOGC87-01</li> <li>1x Fitness Plate - TGOGC23-11</li> </ul>
Spinning Bike	<ul style="list-style-type: none"> <li>1x M16x20 Pin Torx CSNYK - Pedal end cap</li> <li>1x M16x16 Pin Torx Button Head - Top clad</li> <li>2x M16x16 Pin Torx CSNYK - Clads</li> <li>2x M16x40 Pin Torx Hex CSNYK - Central fix</li> </ul>	<ul style="list-style-type: none"> <li>1x Pedal Asm - TGOGC07-017</li> <li>1x End Cap - TGOGC88-06</li> <li>1x Fitness Plate - TGOGC23-11</li> </ul>
Recumbent Bike	<ul style="list-style-type: none"> <li>1x M16x20 Pin Torx CSNYK - Pedal end cap</li> <li>2x M16x16 - Clads</li> <li>1x M16x16 Pin Torx Button Head - Top clad</li> <li>2x M16x20 Pin Torx CSNYK - Clads</li> <li>2x M16x40 Pin Torx Hex CSNYK - Central fix</li> </ul>	<ul style="list-style-type: none"> <li>1x Pedal Asm - TGOGC07-017</li> <li>1x Handle End Cap - TGOGC88-06</li> <li>1x Fitness Plate - TGOGC23-11</li> </ul>
Module	N/A	<ul style="list-style-type: none"> <li>2x Central Bearing Housing Assembly</li> <li>1x Brake Asm - TGOGC88-A-04</li> </ul>
Phyometric Box	Per Product	Partner Pack
N/A	Per Product	Partner Pack
Leg Press	<ul style="list-style-type: none"> <li>2x M16x16 Pin Torx CSNYK - Stops</li> <li>2x M16x20 Pin Torx CSNYK - Stops</li> <li>2x M16x25 Pin Torx Button - Track Asm</li> <li>2x M16x40 Pin Torx Hex CSNYK - Wheels</li> </ul>	<ul style="list-style-type: none"> <li>1x Track Wheel - 251496 POTH 75_15R</li> <li>1x Bump Stop</li> </ul>
Treadmill	Per Product	Partner Pack
N/A	Per Product	Partner Pack
Step Up	Per Product	Partner Pack
N/A	Per Product	Partner Pack
Oblique	<ul style="list-style-type: none"> <li>2x MS CSK Security Screw (A2)</li> <li>2x MS Washer (A2)</li> <li>2x MS Nylon</li> </ul>	<ul style="list-style-type: none"> <li>2x Drive - 65x44x25-12 (Top Nut)</li> <li>1x Drive - 65x44x25-12 (Plain)</li> </ul>
Bench	<ul style="list-style-type: none"> <li>2x M16x25 Button Security Screw (A2)</li> <li>2x MS Washers (A2)</li> </ul>	Partner Pack
Dip and Leg Raise	<ul style="list-style-type: none"> <li>2x M16x25 Button Security Screw (A2)</li> <li>2x MS Washers (A2)</li> <li>1x M16x16 Button Security Screw (A2)</li> <li>1x MS Washer (A2)</li> </ul>	<ul style="list-style-type: none"> <li>2x Signage</li> </ul>
Ski Machine	<ul style="list-style-type: none"> <li>1x TGOGC72-01</li> <li>2x M16x20 Security Button security screw (A2)</li> <li>1x M16x20 Security CSK screw (A2)</li> <li>1x MS Washer (A2)</li> <li>1x MS Nylon</li> </ul>	<ul style="list-style-type: none"> <li>1x Small End Cap - TGOGC72-01</li> <li>1x Large End Cap - TGOGC83-A-05</li> <li>1x Pin/Fab - TGOGC83-A-05</li> </ul>
CP/RK	<ul style="list-style-type: none"> <li>2x M16x25 Button Security (A2) - Seats &amp; Backs</li> </ul>	<ul style="list-style-type: none"> <li>1x End Cap - TGOGC72-01</li> </ul>

### Energy Recumbent Bike TGO892

It may be necessary at some stage to maintain and access the Parasect board on the USB. The Parasect is the electrical heart of the Cardio Charge (Glow and Flow) Recumbent Bike and is what manages the electricity produced from the equipment. This should rarely need visiting, but in the event it does, TGOCC have provided some basic instructions (below) on how to access it.

The USB is what TGOCC call a consumable item and therefore not warranted by TGO. However, it is a low cost product and is simple to replace.

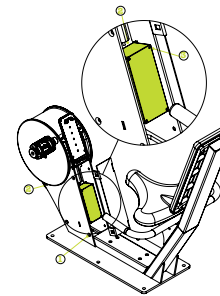

- 1 Remove the four (4) M6 CSunk Pin Torx Screws from the side of the pedal support, to release the rear clad. Place this clad and flange to one side.
- 2 The Parasect will be bolted in a vertically standing position as shown in the diagram. To remove the parasect fully you will need to unscrew the two (2) M6 flange screws from the rear of the Parasect box.
- 3 In order to access the electronics, the Parasect box lid must be removed, by unscrewing the four (4) M6 CSK Pin Torx screws and two (2) M6 CSK Pin Torx screws that hold the lid to the top clad.
- 4 In order to access the electronics, the Parasect box lid must be removed, by unscrewing the four (4) M6 CSK Pin Torx screws and two (2) M6 CSK Pin Torx screws that hold the lid to the top clad.

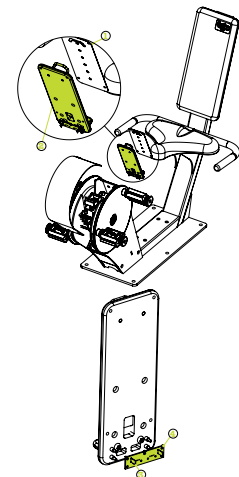

- 1 Remove the stainless steel graphic plate from the console. Use the four (4) Hex Button Pin Torx screws. Retain the screws and put the graphics plate to one side.
- 2 Remove the four (4) now exposed M6x0 CSK Pin Torx Screws which hold the console to the cross trainer frame. Retain the flange in a safe place.
- 3 To remove the USB, unplug the two quad connector ports. Remove the four (4) M6 Nuts and washers, and slide the USB board off the M6 inserts.
- 4 Reapply the new USB board and reverse the above steps to reapply the console.

NOTE 1: Take care as to not damage the casing as the console is pulled away from the cross Trainer.

NOTE 2: Take care as to not damage the casing as the console is pulled away from the cross Trainer.

NOTE 3: The lid screws should be torqued to 5-10Nm in order to retain the IP rating.

NOTE 4: Reverse Procedure to reassemble.



# TGO aftersales service

.....

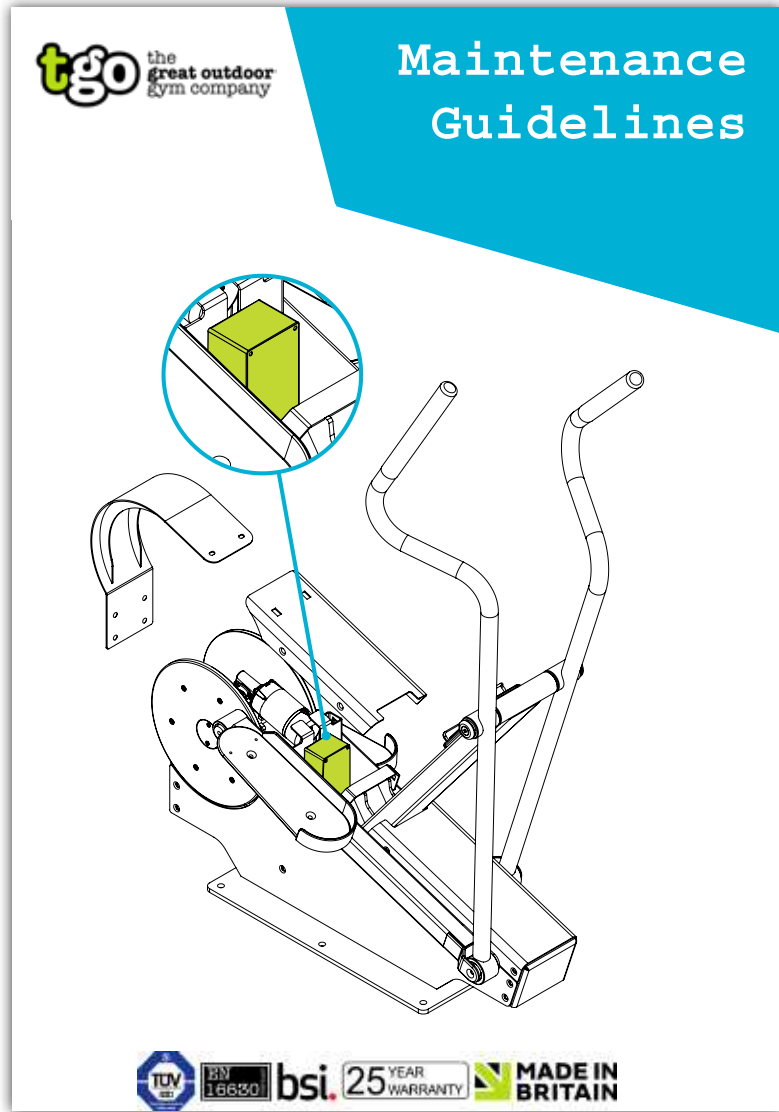

## Maintenance

TGO has been ploughing care into its designs over the past 8 years, ever improving its offer and eradicating known issues. TGO is always aiming for a maintenance free product. However it is important to care for your new gym to ensure it stays in good and safe working order.

TGO is prepared to wrap in maintenance if a number of gyms are purchased.....

## Our promise for your gym aftercare

- Provide you with all the necessary tools to keep your gym in great condition
- Provide you with support and training
- Ensure all consumable elements are available to you in under 72 hours
- Provide you with great warranties
- If a part should break under warranty we will supply a replacement or a fix without any quarms within 4 weeks







JOIN THE *Movement*

JOIN THE BIG COMMUNITY WORKOUT HERE EVERY SATURDAY

DOWNLOAD REGISTER ACTIVATE BE EMPOWERED

FOR EVERYONE ALL AGES & ABILITIES IT'S FREE BRING A FRIEND RECLAIM YOUR HEALTH IT'S NEVER TOO LATE TO START

TGOGC TGOGyms @TGO\_Outdoor Cyms

ACTIVATE

AM

tgo

QR CODE

ACTIVATE



Thank you for taking the time to read through this document.

**We do hope that you choose British design, innovation and manufacturing.**

**Sustainable Wellness**

Activate your community

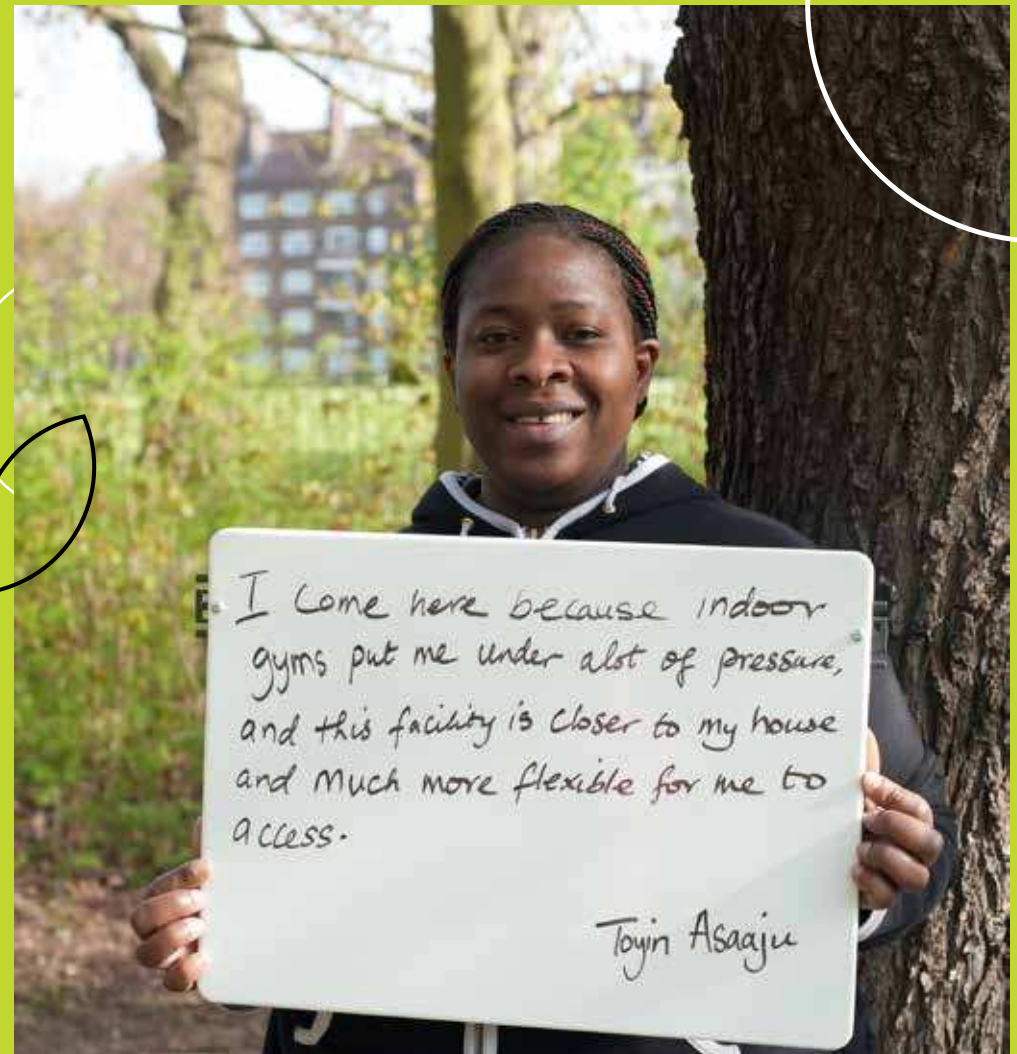

## 1. DEFINITIONS

Business Day: A day (other than a Saturday Sunday or Public Holiday) when banks in London are open for business.

Conditions: The Terms & Conditions set out in this document as amended from time to time.

TGO: The Great Outdoor Gym Company Ltd registered in England and Wales with Company Number: 6041524.

Contract: The Contract between TGO and the Customer for the sale and purchase of the goods or the sale and purchase and installation of the goods in accordance with these Conditions.

Customer: The person, firm, corporate body or public sector authority who purchases the goods from TGO.

Force Majeure Event: An event of circumstance beyond the party's reasonable control.

Goods: The Goods (or any part of them) set out in the order.

Order: The Customer's Order for the Goods as set out in the Customer's purchase order form or the Customer's written acceptance of TGO's quotation.

Specifications: Any Specification for the Goods including any related plans and drawings provided by TGO.

## 2. INTERPRETATION

(a) A reference to a statute or statutory provision is a reference to such statute or provision as amended or re-enacted. A reference to a statute or statutory provision includes any subordinate legislation made under that statute or statutory provision as amended or re-enacted.

(b) Any phrase introduced by the terms including, include, in particular or any similar expression shall be construed as illustrative and shall not limit the sense of the words preceding those terms.

(c) A reference to writing, written or includes emails.

## 3. BASIS OF CONTRACT

3.1 These conditions apply to the Contract to the exclusion of any other terms that the Customer seeks to impose or incorporate, or which are implied by trade, custom, practice or course of dealing.

3.2 The Order constitutes an offer by the Customer to purchase the Goods in accordance with these Conditions. The Customer is responsible for ensuring that the terms of the Order are complete and accurate.

3.3 The Order shall only be deemed to be accepted when TGO issues an acknowledgement of order at which point the Contract shall come into existence.

3.4 The Customer waives any right it might otherwise have to rely upon any terms endorsed upon, delivered with or contained in any documents of the Customer that is inconsistent with these Conditions.

3.5 Any samples, drawings, descriptive matter or advertising produced by TGO and any descriptions or illustrations contained in TGO's catalogues or brochures are produced for the sole purpose of giving an approximate idea of the goods referred to in them. They shall not form part of the Contract nor have any contractual force.

3.6 A quotation for the Goods given by TGO shall not constitute an offer. A quotation shall only be valid for a period of 20 business days from its date of issue.

## 4. GOODS

4.1 The Goods are described in TGO's catalogue as modified by any item or change specified in the quotation produced by TGO.

4.2 TGO reserves the right to amend the Specification of the Goods if required by any applicable statutory or regulatory requirements.

## 5. DELIVERY

5.1 TGO supplies its Goods on an ex works basis. The Customer shall collect the Goods from TGO's manufacturer's premises or such other location as may be advised by TGO prior to collection within 3 business days of TGO notifying the Customer that the Goods are ready.

5.2 Delivery is completed on the completion of loading of the Goods at the collection location.

5.3 Any dates quoted for delivery are approximate only and the time of delivery is not of the essence. TGO shall not be liable for any delay in delivery of the Goods that is caused by a Force Majeure Event or the Customer's failure to provide TGO with any instructions that are relevant to the supply of the Goods.

5.4 If TGO fails to deliver the Goods its liability shall be limited to the costs and expenses incurred by the customer in obtaining replacement Goods of similar description and quality in the cheapest market available, less the price of the Goods. TGO shall have no liability for any failure to deliver the Goods to the extent that such failure is caused by a Force Majeure Event or the Customer's failure to provide TGO with adequate instructions which are relevant to the supply of the Goods.

5.5 If the Customer fails to collect the Goods within 3 business days of TGO notifying the Customer that the Goods are ready, then, except where such failure or delay is caused by a Force Majeure Event or TGO's failure to comply with its obligations under the Contract:

(a) Delivery of the Goods shall be deemed to have been completed at 9.00am on the third business day after the day on which TGO notified the Customer that the Goods were ready; and

(b) TGO shall store the Goods until collection takes place and charge the Customer for all related costs and expenses

5.6 If 15 business days after the day on which TGO notified the Customer that the Goods were ready for collection and the Customer has not made collection of the Goods TGO may resell or otherwise dispose of part or all of the Goods and after deducting reasonable storage and selling costs account to the Customer for any excess over the price of the Goods or charge the Customer for any shortfall below the price of the Goods.

5.7 TGO may deliver the goods by up to 3 instalments which shall be invoiced and paid for separately. Any delay in delivery or defect in an instalment shall not entitle the customer to cancel any other instalment.

5.8 In the event of any of the Goods collected by the Customer being damaged the Customer must report that damage to TGO on the same day as collection.

5.9 In the event of TGO agreeing to deliver the Goods to the Customer and in the event of those Goods being found to be damaged the Customer must report the damage to TGO on the same day as delivery to the Customer.

5.10 If the Customer fails to report damage as required by Clauses 5.8 and 5.9 TGO shall not be liable to the Customer for any loss arising from the damage.

## 6. QUALITY

6.1 TGO warrants that on delivery and for a period of 12 months from the date of delivery (warranty period) the Goods shall:

(a) Conform in all material respects with their description; and

(b) be free from material defects in design material and workmanship; and

6.2 TGO further warrants components of its Goods:

25 YEAR WARRANTY on the structural integrity of steel posts, all welds, bars and steel structural equipment.

10 YEAR WARRANTY against significant corrosion on galvanised products, which are erected at least 250m from the coastline.

5 YEAR WARRANTY on galvanised products, which are situated within 250m of the coastline.

5 YEAR PAINT WARRANTY for paintwork against material fade from exposure to ultra violet light.

1 YEAR WARRANTY on green energy gym electronics excluding batteries and USB ports.

2 YEAR WARRANTY on bearings and bearing cases.

2 YEAR WARRANTY on plastic or composite parts, seats and fittings and clamps.

1 YEAR WARRANTY on gears.

Rubber handles, USB ports, batteries and polyurethane traveller wheels are not covered by warranty but should be replaced during maintenance if required.

6.3 The warranties given in 6.1 and 6.2 above are made upon the following conditions:

(a) The Warranty begins from the date of dispatch from the TGO warehouse.

(b) Customers must satisfy themselves that they can carry out the maintenance instructions proficiently using adequately trained engineers.

(c) These warranties do not cover installation faults. Customers must satisfy themselves that installations have been carried out in accordance with the installation instructions specified by TGO.

(d) TGO shall replace faulty products by sending the replacement part to a designated warehouse. TGO shall pay for posting and packaging. The customer may be required to return the faulty part within 30 days at their own cost.

(e) The Customer must pay for the labour cost of the maintenance engineer to carry out all works necessary to diagnose, extract the faulty part, leave the site safe and reinstall safely the replacement part.

(f) The Customer shall assess the risk of the site pending repair or during repair to ensure that there is no risk to the health and safety of the general public.

(g) In the event of the Customer or appointed maintenance contractor not carrying out its maintenance obligations as set out in TGO's maintenance instructions published from time to time by TGO on its website or in writing these warranties shall be null and void. TGO shall be entitled to request to see the Customer's maintenance log books from time to time with the names, dates and signatures of engineers.

(h) Non galvanised product must not be situated within 1km of the coast.

(i) The warranties do not cover damage caused by accident, negligence, normal wear and tear, failure to maintain or misuse.

(j) The Customer must report all warranty claims within 14 days. The report to TGO must include correct name of product, installation date, a photo of the manufacturing label, photographic evidence and clear description of issues.

(k) The Customer may assign the benefit of the guarantee to a purchaser of or a successor of title to the gym equipment provided that the Customer sends within 4 weeks of the assignment a copy of the same to TGO plus a fee of £75 plus vat.

(l) TGO shall not be liable for any consequential loss or damage arising from the failure of the equipment other than for loss or damage which arise from personal injury or death for which no limit on liability is placed.

(m) The warranties do not cover consumable items.

6.4 Except as provided in this clause TGO shall have no liability to the Customer in respect of the Goods failure to comply with the warranty set out in Clause 6.1.

6.5 The terms implied by Sections 13 to 15 of the Sale of Goods Act 1979 are, to the fullest extent permitted by law, excluded from the Contract.

6.6 The Conditions shall apply to any repaired or replacements Goods supplied by TGO.

6.7 The TGO Warranties do not apply to branded goods bought in from other manufacturers to fill the customer's order. The liability of TGO in relation to those goods is limited to the warranty provided by those manufacturers.

6.8 No warranty against corrosion is given for any product galvanised or not which is in direct and regular contact with chlorinated water salt water or salt spray.

## 7. SAFETY

7.1 Customers must ensure that all Goods purchased from TGO are installed by competent workmen using high quality materials and in accordance with Standard EN16630.

7.2 Immediately following the installation of the Goods referred to above the Customer must arrange for the installation to be inspected by a Registered Play Inspector and obtain a certificate that the installation is safe and has been made in accordance with Standard EN16630 and TGO's installation manual.

7.3 In the event of any fault occurring in any of the Goods the Customer shall take out of service to the public the product to which the fault relates until the faulty product has been repaired/replaced.

7.4 TGO shall be entitled to send to the customer product defect warnings and in the event of the Customer receiving any such warning the Customer shall act on the recommendations of TGO incorporated within the product warning so as to ensure that there is no risk of the fault becoming a risk to safety.

7.5 TGO shall be entitled to require the Customer to change the signage relating to any of the Goods and in the event of this right being exercised by TGO the replacement signage shall be provided free of charge.

## 8. TITLE AND RISK

8.1 The risk in the Goods shall pass to the Customer on collection.

8.2 Title to the Goods shall not pass to the Customer until the earlier of;

(a) TGO receives payment in full for the Goods and

(b) The Customer resells the Goods in which case the title to the Goods shall pass to the Customers immediately before that resale has taken place.

## 9. PRICE AND PAYMENT

9.1 The price of the Goods shall be the price set out in the Order

9.2 The price of the Goods;

(a) Excludes amounts in respect of Value Added Tax (VAT) which the customer shall additionally be liable to pay to TGO at the prevailing rate, subject to the receipt of a valid VAT invoice and

(b) Excludes the costs and charges of packaging insurance and transport of the Goods.

9.3 The Customer shall pay the invoice in full within 30 days of the date of the invoice. Payment shall be made to the bank account nominated in writing by TGO

9.4 If the Customer fails to make any payment due to TGO under the Contract by the due date for payment then the Customer shall pay interest on the overdue amount at the rate of 10% per annum. Such interest shall accrue on a daily basis from the due date until actual payment of the overdue amount, whether before or after judgement. The Customer shall pay the interest together with the overdue amount.

9.5 The Customer shall pay all amounts due under the contract in full without any set-off, counterclaim, deduction or withholding (except for any deduction or withholding required by law). TGO may at any time without limiting any other rights or remedies it may have, set off any amount owing to it by the customer against any amount payable by TGO to the Customer.

9.6 In the event of the Customer cancelling the order made by the Customer and that cancellation is received by TGO before the Goods have been delivered by TGO to the Customer or collected by the Customer the Customer shall pay to TGO by way of liquidated and ascertained damages 50% of the price of the Goods within 14 days from the date of cancellation.

9.7 In the event of the Customer cancelling the order made by the Customer after the Goods have been delivered by TGO to the Customer or collected by the Customer the Customer shall pay to TGO 100% of the price within 28 days from delivery of the Goods to the Customer or collection of the Goods by the Customer.

10. INSTALLATION



10.1 This entire clause shall only apply to Contracts where TGO has agreed with the customer to install TGO Goods at a site nominated by the Customer.

10.2 In the event that this clause does apply and it then being found that there is a conflict between this clause and other clauses in these Terms and Conditions the provision made under this clause shall prevail.

10.3 The Customer shall obtain prior to commencement of the installation all necessary Consents statutory or otherwise required for the works of installation.

10.4 TGO will execute the works of installation using good and sound materials and in a proper and workmanlike manner.

10.5 The customer shall pay to TGO the price of the Goods and installation 30 days from the date of practical completion.

10.6 TGO shall certify the date of practical completion.

10.7 The risk in the Goods shall vest in the Customer as from the date of practical completion and the Public Liability risk in the installation as a whole shall vest in the Customer as from the date of practical completion.

10.8 The customer warrants that the ground conditions for the intended installation contain no special adverse properties or features. Should it be discovered that the Customer's site does have adverse properties or features TGO's surveyor shall define those adverse properties or features and the cost of overcoming the same so that the installation may proceed.

10.9 TGO will provide the customer with a copy of the report from the surveyor. The Customer will have 10 days in which to accept the report and pay for the additional works, or terminate the Contract by paying 25% of the contract Price in compensation.

10.10 In the event of the Customer electing to terminate the contract pursuant to clause 9.9 above the property in the Goods will remain with TGO and not with the Customer.

## 11 TERMINATION

11.1 Without limiting its other rights or remedies, TGO may terminate the Contract with immediate effect by giving a written notice to the Customer if:

- (a) The Customer commits a material breach of any term of the Contract and (if such a breach is remediable) fails to remedy that breach within 10 Business Days of that party being notified to do so;
- (b) The Customer takes any step or action in connection with its entering administration, provisional liquidation or any composition or arrangement with its creditors (other than in relation to a solvent restructuring), being wound up (whether voluntarily or by Order of the Court, unless for the purpose of a solvent restructuring), having a receiver appointed to any of its assets or ceasing to carry on business.
- (c) The Customer suspends, threatens to suspend, ceases or threatens to cease to carry on all or a substantial part of its business or
- (d) The Customer's financial position deteriorates to such an extent that in TGO's opinion the Customer's capability to adequately fulfil its obligations under the Contract have been placed in jeopardy.

11.2 Without limiting its other rights or remedies, TGO may suspend provision of the Goods under any Contract it may have with the Customer if the Customer becomes subject to any of the events listed in clause 11.1(a) to Clause 11.1(d) or TGO reasonably believes that the Customer is about to become subject to any of them or if the Customer fails to pay any amount due under the contract on the due date for payment.

11.3 On termination of the contract for any reason the Customer shall immediately pay to TGO all of TGO's outstanding unpaid invoices and interest.

## 12 LIMITATION OF LIABILITY

12.1 nothing in these conditions shall limit or exclude TGO's liability for:

- (a) Death or personal injury caused by its negligence or the negligence of its employees, agents or sub-contractors
- (b) Fraud or fraudulent misrepresentation.
- (c) Breach of the terms implied by Section 12 of the Sale of Goods Act 1979 or
- (d) Defective products under the Consumer Protection Act 1987 or
- (e) Any matter in respect of which it would be unlawful for TGO to exclude or restrict liability.

12.2 Subject to Clause 11.1:

- (a) TGO shall under no circumstances whatsoever be liable to the Customer, whether in Contract, tort (including negligence), breach of statutory duty, or otherwise, for any loss of profit on any indirect or consequential loss arising under or in connection with the Contract and
- (b) TGO's total liability to the Customer in respect of all other losses arising under or in connection with the Contract whether in Contract, tort (including negligence), breach of duty, or otherwise, shall in no circumstances exceed 150% of the price of the Goods.

## 13 FORCE MAJEURE

Neither party shall be in breach of contract nor liable for delay in performing, or failing to perform, any of its obligations under the Contract if such delay of failure result from a Force Majeure Event. If the period of delay or non-performance continues for 13 weeks then either party may terminate the Contract by giving 2 weeks written notice to the other.

## 14 GENERAL

14.1 Assignment and other dealings.

- (a) TGO may at any time assign, transfer, mortgage, charge, sub-contract or deal in any manner with all or any of its rights or obligations under the contract.
- (b) The Customer may not assign, transfer, mortgage, charge, sub-contract, declare a trust over or deal in any other manner with any or all of its rights or obligations under the contract without the prior written consent of TGO.

14.2 Entire Agreement.

- (a) The Contract constitutes the entire agreement between the parties and supersedes and extinguishes all previous agreements, promises, assurances, warranties, representations and understandings between them, whether written or oral, relating to its subject matter.
- (b) Each party agrees that it shall have no remedies in respect of any statement, representation, assurance or warranty (whether made innocently or negligently) that is not set out in this agreement.

14.3 Variations

No variation of the Contract shall be effective unless it is in writing and signed by a director of TGO or an authorised representative of the Customer

14.4 Severance

If any provision or part-provision of the Contract is or becomes invalid, illegal or unenforceable, it shall be deemed modified to the minimum extent necessary to make it valid, legal and enforceable. If such modification is not possible, the relevant provision or part-provision shall be deemed deleted. Any modification to or deletion of a provision or part-provision under this clause shall not affect the validity or enforceability of the rest of the Contract.

14.5 Notices

- (a) Any notice or other communication given to a party under or in connection with the Contract shall be in writing addressed to its principle place of business or such other address as that party may have specified to the other in writing in accordance with this clause and shall be delivered personally, sent by pre-paid 1st Class post or other next working day delivery service, commercial courier, or email.
- (b) The provisions of this clause shall not apply to the service of any proceedings or other documents in any legal action.

14.6 Third Party Rights

No one other than a party to this Contract and their permitted assignees shall have any right to enforce any of its terms.

14.7 Governing Law

The contract and any dispute or claim arising out of or in connection with it or its subject or formation shall be governed by and construed in accordance with the law of England and Wales.

14.8 Jurisdiction

Each party irrevocably agrees that the Courts of England and Wales shall have exclusive jurisdiction to settle any dispute or claim arising out of or in connection with the Contract or its subject matter or formation.



File Message Help Tell me what you want to do

Ignore Delete Archive Reply Reply Forward More - Meeting

Rules - To Manager

Team Email Reply & Delete

Create New

Move OneNote Mark Follow

Unread Tags

Translate Related - Select -

Read Aloud Zoom

Speech Zoom

clerk@goudhurst-pc.gov.uk assistantclerk@goudhurst-pc.gov.uk Mon 11

**FW: Quarry pond duck weed and tree.**

**To:** [clerk@goudhurst-pc.gov.uk](mailto:clerk@goudhurst-pc.gov.uk)  
**Subject:** FW: Quarry pond duck weed and tree.

---

**From:** John Fermor <[john\\_fermor@hotmail.co.uk](mailto:john_fermor@hotmail.co.uk)>  
**Sent:** 20 June 2024 17:09  
**To:** [rebeccabarden@goudhurst-pc.gov.uk](mailto:rebeccabarden@goudhurst-pc.gov.uk)  
**Cc:** Panetta Horn <[rfo@goudhurst-pc.gov.uk](mailto:rfo@goudhurst-pc.gov.uk)>  
**Subject:** Quarry pond duck weed and tree.

Dear Rebecca and Panetta,  
Following on from the telephone conversation I had with you concerning the Duck weed and fallen tree in the quarry pond I can now give you a quote regarding this.

The water level is quite high at present and removing the tree at this time would be difficult and risky . It has been there for quite sometime and does not pose a hazard although unsightly. As the summer progresses and the water level drops we could cut this up and remove it without any problems.  
The Cost to do this work would be £180.

The Duck weed which can reproduce every 16hrs poses a more awkward situation. In the past we have put a boom across the pond and dragged the weed carefully down to one end of the pond and then removed the weed manually .This can be done from either side of the bank. At this time of the year with long daylight hours the weed does grow quickly and to keep the pond looking reasonably clear this process needs to be repeated every 3 or 4 weeks into September. Then as the water in the pond starts to cool down and the daylight decreases the weed slows down.

The Cost to remove this weed using this method would be £280 per visit.

I hope this is information is useful.

Kind regards John Fermor  
Sent from [Mail](#) for Windows